

Service Manual

MONiMAX2800SE System

V01.00.02 (2019.03.05)



Contents

Chapter1. Preface

| | |
|------------------------------|-----|
| Purpose | 1-1 |
| Audience..... | 1-1 |
| Supported Information | 1-1 |
| What is in This Manual | 1-1 |
| Terminologies | 1-2 |
| Abbreviations | 1-2 |
| Safety Precautions | 1-4 |
| Related Documents | 1-6 |
| Overview..... | 1-7 |
| Basic Features..... | 1-8 |

Chapter2. System Configuration

| | |
|-----------------------------|-----|
| About the MX2800SE | 2-1 |
| The Exterior Overview | 2-2 |
| Hardware Configuration..... | 2-3 |

Chapter3. User Handling Unit

| | |
|------------------------------------|------|
| Overview..... | 3-1 |
| Operation Panel for Customer | 3-1 |
| Modem Board | 3-10 |
| Cortex Mainboard | 3-12 |
| Mini HUB Board..... | 3-15 |
| Encryption PIN Pad | 3-18 |

Chapter4. Power Supply

| | |
|--------------------------------------|-----|
| General Description and Scope | 4-1 |
| Input Electrical Specifications..... | 4-1 |
| Output Electrical Requirements..... | 4-2 |
| Environmental Requirement..... | 4-5 |

Chapter5. Cash Dispenser Unit

| | |
|-------------|------|
| CDU-L3..... | 5-1 |
| CDU-M..... | 5-25 |
| CDU21 | 5-53 |

Chapter6. Receipt Printer

| | |
|---|------|
| Overview..... | 6-1 |
| Appearance and Dimension | 6-2 |
| Basic Specifications | 6-3 |
| Specifications of DIP S/W | 6-4 |
| Functional Description | 6-5 |
| Mechanical Adjustment..... | 6-7 |
| Preventive Maintenance | 6-9 |
| Removal/Installation Procedure for Field Technician | 6-15 |

| | |
|-------------|---------|
| Notes | Notes-1 |
|-------------|---------|

Contents

| | |
|------------------------------|-----|
| Purpose | 1-1 |
| Audience..... | 1-1 |
| Supported Information | 1-1 |
| What is in This Manual | 1-1 |
| Terminologies..... | 1-2 |
| Abbreviations | 1-2 |
| Safety Precautions..... | 1-4 |
| Related Document..... | 1-6 |
| Overview | 1-7 |
| Basic Features..... | 1-8 |

Purpose

- ▶ This manual is produced to provide the MX2800SE maintenance guide for field technician.

Audience

- ▶ This manual is for persons related to maintain MX2800SE in branches of banks, such as field technician and repair center engineer, to work efficiently and conveniently.

Supported Information

- ▶ If any question or error occurs while maintaining MX2800SE in compliance with this manual, please contact maintenance staffs of Hyosung TNS.
For the contact of maintenance staffs of Hyosung TNS, see the E-mail addresses and telephone numbers provided separately.

What is in This Manual

- ▶ MONiMAX referred to as “MX”
- ▶ This manual is designed to provide the maintenance guide for the MX2800SE and the detailed description of the following:
 - Important Warnings
 - Information for service & maintenance
- ▶ All information described in this manual is a licensed product of Hyosung TNS.

Some of the information in this manual may differ according to the network processor to be connected and may be subsequently updated by the bank's needs or the improvement by Hyosung TNS.

It is the policy of Hyosung TNS to improve products as new technology, components, software, and firmware become available. Therefore Hyosung TNS reserves the right to change specifications without notice.

Terminologies

- ▶ In this document the terminology listed below is used as follows:
 - Customer and consumer refer to any person who transacts business through the ATM.
 - Device and unit refer to the standard and optional ATM equipment, such as monitor, card reader, printer and dispenser.
 - Fascia refers to the entire front portion of the unit, including the portion where the customer transacts business.
 - Module refers to a plug-in device that can be serviced or replaced.
 - Note(s) and bill(s) refer to the individual documents loaded into and dispensed from the dispenser.
 - Servicing and maintenance refer to the supervisor, operator and technician's tasks performed to keep the ATM operational.
 - Screen refers to the text appearing on the customer display.

Abbreviations

- ▶ In this document the abbreviations listed below is used as follows:

| # | Abbreviations | Description |
|----|---------------|---|
| 1 | AD board | Analog to Digital conversion Board |
| 2 | ADA | The American Disabilities Act |
| 3 | AP | Application Program |
| 4 | Assy | Assembly |
| 5 | BATT S/W | Battery Switch |
| 6 | CAM | Camera Unit |
| 7 | CDU | Cash Dispenser Unit |
| 8 | CE | Control Electronics |
| 9 | Earphone Jack | Voice Converter for Visually Disabled Persons (ADA) |
| 10 | EMV | Europay, Mastercard, Visa |
| 11 | EP | Elementary Program |
| 12 | EPP | Encryption PIN Pad |
| 13 | H/W | Hardware |
| 14 | I/F | Interface |
| 15 | ISO | International Standard Organization |
| 16 | JPR | Journal Printer |
| 17 | LCD | Liquid Crystal Display |
| 18 | MCU | Magnetic Card Unit |
| 19 | OPL | Operation Panel for Customers to Operate |
| 20 | OSD board | On Screen Display Board |

| # | Abbreviations | Description |
|----|---------------|----------------------------------|
| 21 | P/S | Power Supply |
| 22 | PIN | Personal Identification Number |
| 23 | PNC | Panel Control Board |
| 24 | PTR | Printer (mainly Receipt Printer) |
| 25 | SW | Switch |
| 26 | SIU | Sensor and Indications Unit |
| 27 | SP | Service Provider |
| 28 | SPR | Slip Printer (Receipt Printer) |
| 29 | TTU | Text Terminal Unit (OPL or SPL) |
| 30 | VFD | Vacuum Fluorescent Display |

Safety Precautions

► Common Safety Precaution





Precautions outlined in this manual provide information on safe and proper handling of the product. Non-compliance of the precautions may result in injury or damage to the product. This precaution symbol with sample term tells you safety warnings during equipment handling.





- Please read the following instructions before operating equipment.
 - Operate equipment in the order outlined in this manual.
 - Follow precautions indicated in this manual, as well as the equipment itself. Failure to properly address these precautions may lead to injury or damage to the product.
 - Avoid operations not addressed in this manual.
 - If you cannot remedy system problems using the methods outlined in this manual, please refer to contact information listed in the manual.
 - Any change or modifications in construction of this device which are not expressly approved by the party responsible for compliance could void the user's authority to operate the equipment.

<Note!>

This equipment has been tested and found to comply with the limits for a Class A digital device, pursuant to part 15 of the FCC Rules. These limits are designed to provide reasonable protection against harmful interference when the equipment is operated in a commercial environment. This equipment generates, uses, and can radiate radio frequency energy and, if not installed and used in accordance with the instruction manual, may cause harmful interference to radio communications. Operation of this equipment in a residential area is likely to cause harmful interference in which case the user will be required to correct the interference at his own expense.

► Description of Precaution Symbols

| Symbol | Description |
|---|---|
|  | <p>Electrical Shock Warning</p> <ul style="list-style-type: none"> ▪ Do not remove cover. Only a maintenance engineer is allowed to open the cover. ▪ Do not touch. You may receive electric shock. ▪ Make sure to turn off the power when servicing the equipment. |
|  | <p>High Temperature Warning</p> <ul style="list-style-type: none"> ▪ Do not touch the equipment when it is running. ▪ The equipment can get extremely hot and may cause a burn. ▪ Make sure to close the cover before running the equipment. |

| | |
|---|--|
|  | <p>Use Precaution when Moving</p> <ul style="list-style-type: none"> ▪ The equipment is heavy. Make sure at least 2 people lift or move the equipment. ▪ Do not attempt to move the equipment alone. You may be injured from dropping the heavy equipment. |
|  | <p>Fire Hazard</p> <ul style="list-style-type: none"> ▪ Place the equipment in an area away from any combustible materials. ▪ The equipment may catch on fire from overheating or short circuit of the power supply unit. |
|  | <p>Disassembly Warnings</p> <ul style="list-style-type: none"> ▪ Do not disassemble or modify the equipment unless you are a certified engineer. ▪ Contact the service center for maintenance, adjustments and repairs. ▪ Improper disassembly may cause fire or electrical shock. |
|  | <p>Collapse Precautions</p> <ul style="list-style-type: none"> ▪ Do not place the equipment where the floor cannot sustain the weight of the equipment, or on slanted or unstable surface. ▪ Equipment may fall and cause injury or damage. |
|  | <p>Unplug the Equipment</p> <ul style="list-style-type: none"> ▪ Stop using the equipment immediately if it smokes, emits an unusual smell, makes abnormal sounds, or if liquids or other foreign materials enter the equipment. ▪ If the above-mentioned abnormalities occur, immediately turn off the power, unplug the equipment and contact the service center. ▪ If you ignore these symptoms, the equipment may catch on fire or cause electric shock. |

<CAUTION>

1. To reduce the risk of fire, use only No. 26 AWG OR LARGER Telecommunication cord
2. Risk of explosion if battery is replaced by an incorrect type.
Dispose used batteries according to the instructions.
3. For pluggable equipment, the socket-outlet shall be installed near the equipment and shall be easily accessible. (Pour les équipements enfichables, la prise de courant doit être installée à proximité de l'équipement et doit être facilement accessible.)
4. The equipment is to be secured to the building structure before operation.
5. A security container shall be permitted to optionally be provided with a secondary lock, but improper use of the secondary lock feature will reduce the security level of the ATM.

Related Document

- ▶ The related documents are listed as follows. If needed, please contact staffs of our technical support team and maintenance team.
 - Installation Manual
 - Operator Manual
 - Error Code Manual
 - Op Function Manual
 - Quick Reference Guide

Overview

- ▶ This manual is designed to provide maintenance guide for the MX2800SE ATM and provide detailed description of the following:
 - System configuration
 - Specification of each unit
 - Facility specifications

All information described in this manual is a licensed product of Hyosung TNS. It is the policy of Hyosung TNS to improve products as new technology, components, software, and firmware become available. Therefore Hyosung TNS reserves the right to change specifications without notice.

Basic Features

- Important features of the MX2800SE is highlighted in the following list:

<Note!>

1. Your MX2800SE may not contain all the devices described in this section. Some devices are optional and some devices cannot be used in combination with other devices (mutually exclusive combinations).

| Item | | Specification | | | Remarks (Option) | |
|--|---|-------------------------------------|--------------------------------|---------------------|----------------------------------|--------------------------|
| Main Controller (Cortex-A8) | CPU | | CPU : S5PV210 1.0GHz | | | |
| | Memory | DDR2 | 512MB | | 128MB X 4EA (32Bit Interface) | |
| | | NAND Flash | 256MB | | | |
| | Operating System | | Win_CE 6.0 | | | |
| | USB Ports | | USB2.0 1-Port , HUB2.0 4-Port | | | |
| | Serial Ports | | 8-Ports | | | |
| | VGA | | On-Board | | LVDS | |
| | Communication | | Modem & TCP/IP Selectable | | | |
| Customer Display | Display | Type | 12.1" wide TFT LCD(1024*768) | | | |
| | | Brightness | 350 cd/m ² (LED BU) | | | |
| | Privacy Filter | | Option | | Support Option | |
| | Guide Light | Flicker LED | SPR/CDU/MCU/EPP | | | |
| Signage | | LED Inner Signage (ATM) | | | | |
| Customer Input Method | Pin-Pad | | EPP 8000M (PCI3.0 Compliant) | | | |
| | Function Key | | Touch F-key 4 x 2 NDC | | | |
| | Touch Screen | | N/A | | | |
| Cash Dispenser (CDU-L3) (CDU-M) | Number of cassettes & Denomination & Capacity | | CST | Denomination | Capacity | CDU21 (CDU-L3, CDU-M) |
| | | | A | USD 10 or 20 | 1K or 2K | CDU21(\$10) |
| | | | B | USD 20 | 2K | |
| | | | C | USD 20 | 2K | |
| | Maximum Dispense | | 40 Notes/1transaction | | | |
| | Cassette Capacity | | Max. 2,000 notes per cassette | | CDU21(1K) | |
| Reject Type | | Note by Note Reject (200 bills Max) | | | | |
| Card Reader (SANKYO DIP) | Type | | EMV DIP Type | | | |
| | Magnetic Stripe | | ISO 1,2,3 Read | | | |
| | IC card Support | | Support | | | |
| Receipt Printer (SPR23-U) | Printing Type | | Thermal Line Printing | | | |
| | Black Mark Paper Support | | Support | | | |
| | Paper Specification | Type | Thermal Roll Paper | | | |
| | | Width | Max. 80mm | | | |
| | | Outer Diameter | Max. 180Φ | | | |
| Black Mark Paper Support | | Support | | | | |
| Journal | Electronic Journal | | Support | | - | |
| Safety | Specification | | UL Business Hour Safety | | Level-1 Option | |

| | | | | |
|--|----------------------------|---------------|---|--------------------|
| & Security | Locking device | | E- Lock | Cencon Lock Option |
| | System Key | | Common key | |
| | Safety Spec. | Safety Body | Steel Thickness : 2.3t | |
| | | Safety Bottom | Steel Thickness : 6.0t | |
| | | Safety Door | Steel Thickness : 3.0t | |
| | Alarm/Security | | N/A | |
| | Terminal Block | | N/A | |
| Additional function | Audio guidance | | Support | |
| | ADA Volume Control | | N/A | |
| | Heater | | N/A | |
| | RF | | Option | Kiosk-II Option |
| | Camera | | USB Camera(Face) | |
| Power Supply | Main Power Supply | | 100W Free Voltage (90~264VAC) | |
| | Battery | | N/A | |
| Approx. Dimension & Environment | Dimension (HXWXD) | | 1,433 X 400 X 585.5 mm | |
| | Installation | | Front Access/Operation Sample (Caster) Mass Product (Anchor Bolt) | |
| | Weight | | About 130 Kg | |
| | Operational Temperature | Operating | 5°C ~ 35°C | |
| | | Storage | 0°C ~ 40°C | |
| | Operational Humidity | Operating | 25% ~ 85% | |

Chapter 2

System Configuration

Contents

| | |
|------------------------------------|-----|
| About the MX2800SE | 2-1 |
| The Exterior Overview | 2-2 |
| Hardware Configuration..... | 2-3 |
| System Block Diagram | 2-3 |
| System Cable Linking Diagram | 2-4 |

About the MX2800SE

- ▶ MX2800SE is designed to meet the everyday demands of immediate cash needs for individuals with a compact size to fit in virtually any place. This Automated Teller Machine (ATM) is connected to a network processor to verify accounts and any other inquiries through the insertion of a customer's card. MX2800SE is easy to use, easy to service and able to support customer's needs.

- ▶ The benefits that the new concept MX2800SE provides are as follows.

Removes inconvenience which occurs when bank clerks directly handle cash with customers and relieves workload upon tellers by processing withdrawal of cash automatically.

Allows tellers to calculate and close amount faster than the existing manual calculation.

Allows easy and quick installation and maintenance.

The Exterior Overview

- ▶ The following picture shows the front of MX2800SE and key units.
The fascia provides the interface between the customer and MX2800SE.
The customer selects transactions and requests information at the fascia.



Hardware Configuration

System Block Diagram

► System Block Diagram

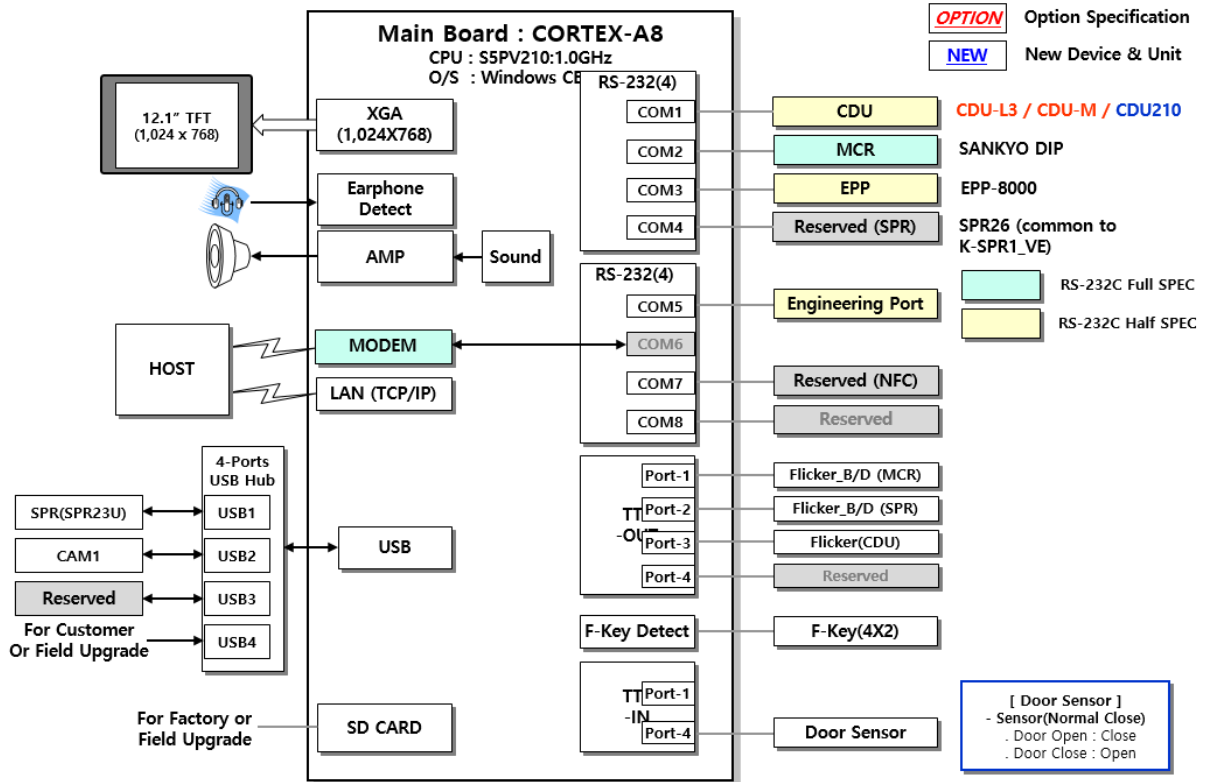

System Cable Linking Diagram

► CE / OPL / Front Panel

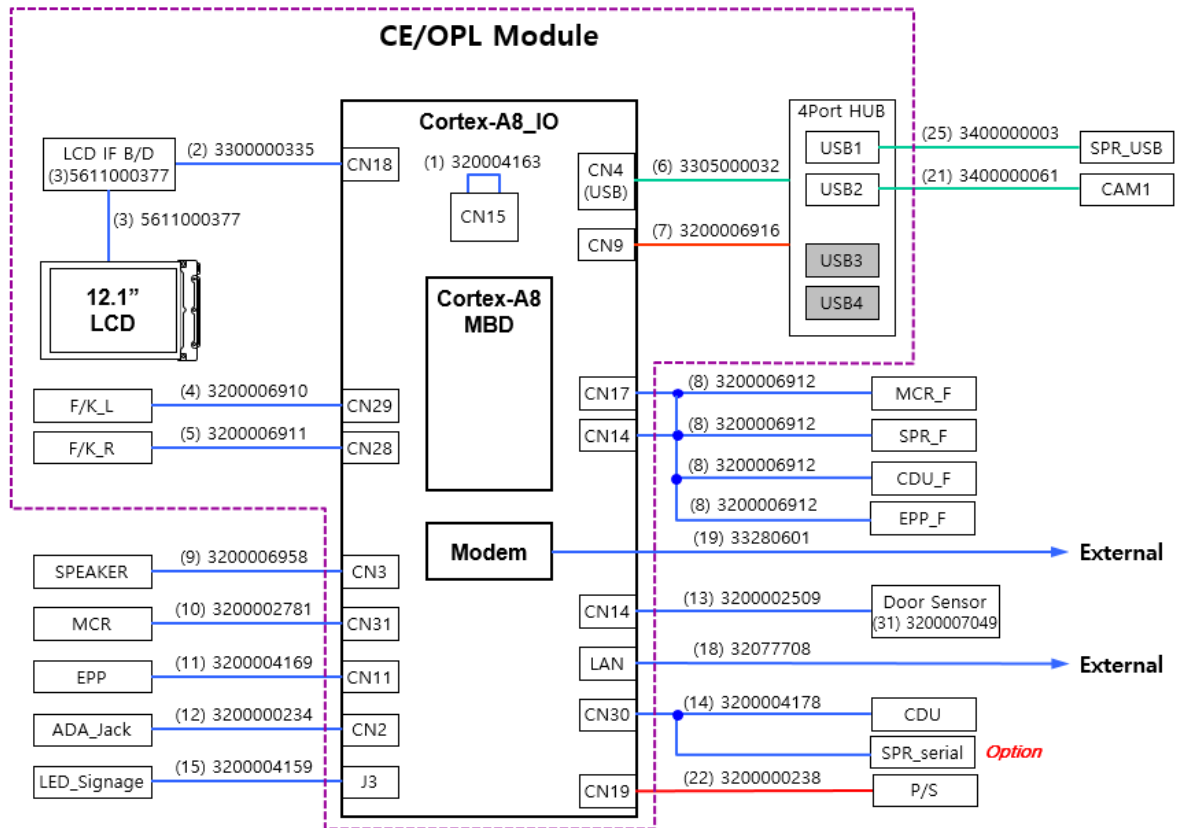

► Power Supply Interface

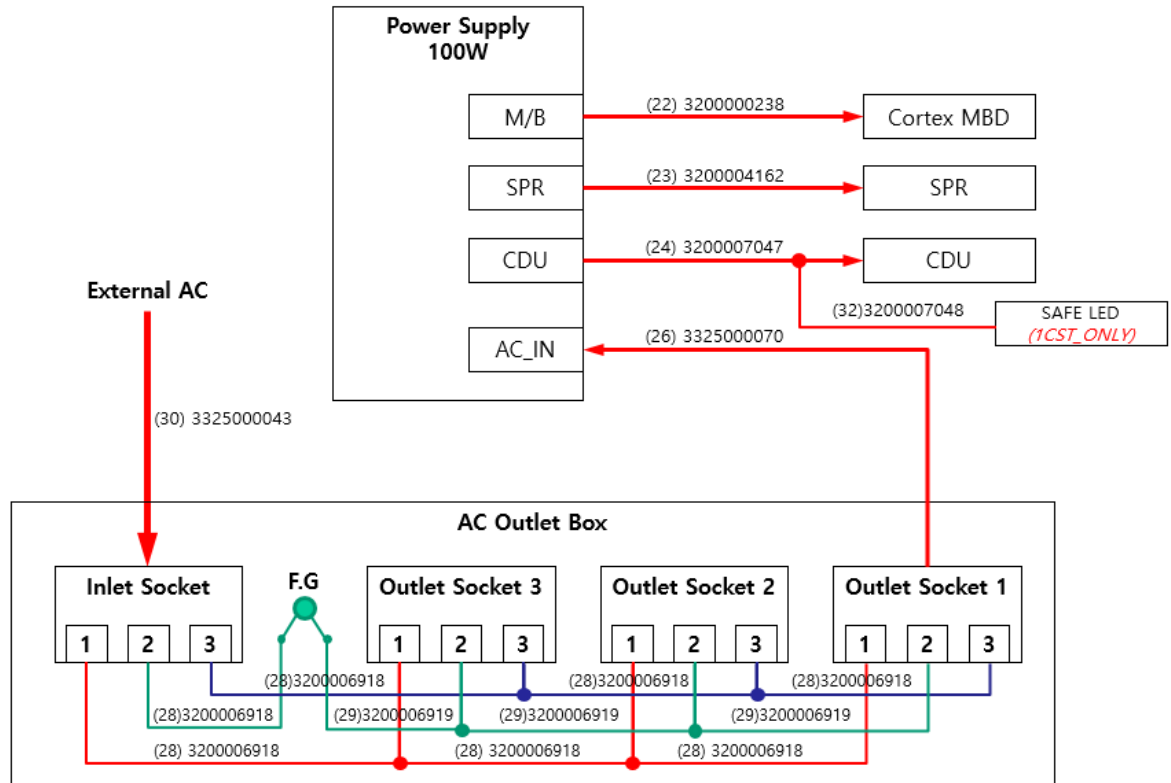

Contents

Overview 3-1

Operation Panel for Customer 3-1

 LCD 3-1

 Basic Specification 3-2

 Functional Block Diagram 3-2

 General Precaution 3-3

 Interface Board 3-5

 Touch Function Key 3-8

Modem Board 3-10

Cortex Mainboard 3-12

 Basic Specification 3-12

 CPU Block Diagram 3-13

 Board Block Diagram 3-14

 Board Layout 3-14

Mini HUB Board 3-15

Encryption PIN Pad 3-18

 Common Occurred Problem List 3-19

 Troubleshooting 3-19

Overview

- ▶ The user handling unit is composed of function key and an encryption PIN pad that the customers use to complete a transaction. It also includes a monitor and associated electronic boards.

Operation Panel for Customer

- ▶ The operation panel includes a LCD, function key and associated electronic boards.

LCD

- ▶ Introduction

The M121GNX2 R1 is a color active matrix thin film transistor (TFT) liquid crystal display (LCD) that uses amorphous silicon TFT as a switching device. It is composed of a TFT LCD panel, a backlight system, column driver and row driver circuit. This TFT LCD has a 12.1-inch diagonally measured active display area with XGA resolution (1024 horizontal by 768 vertical) pixels arrays.

- ▶ Features

- 12.1" TFT LCD Panel
- LED Backlight System
- Supported XGA 1024x768 pixels resolution
- Compatible with RoHS standard

Basic Specification

| Items | Specifications |
|------------------------------|-------------------------------|
| Screen Diagonal | 12.1Inch |
| Active Area | 245.76 (H) x184.32 (V) mm |
| Pixels H x V | 1024(RGB) x768 |
| Pixel Pitch | 0.24(H)x0.24 (V) mm |
| Pixel Arrangement | R.G.B. Vertical Stripe |
| Display Mode | Normally White |
| Normally White | 350 (TYP) cd /m ² |
| Contrast Ratio | 800 (TYP) |
| Response Tim | 16 (TYP) msec |
| Input Voltage | 3.3V |
| Power Consumption | 6.925 (Max) W |
| Weight | 545 (Max) g |
| Outline Dimension | 279.0(H) x209.0(V) x9.0(D) mm |
| Electrical Interface (Logic) | LVDS |
| Support Color | 262K/16.7M |
| Optimum Viewing Direction | 6 o'clock |
| Surface Treatment | Anti-glare & hardness 3H |

Functional Block Diagram

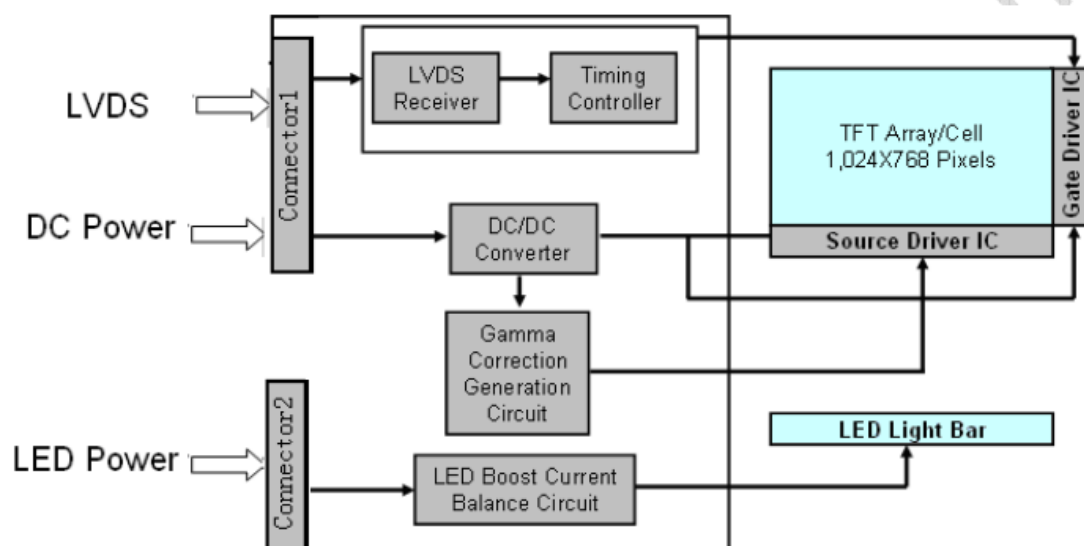

General Precaution

► Use Restriction

This product is not authorized for use in life supporting systems, aircraft navigation control systems, military systems and any other application where performance failure could be life-threatening or otherwise catastrophic.

► Handling Precaution

1. Please mount LCD module by using mounting holes arranged in four corners tightly.
2. Do not disassemble or modify the module. It may damage sensitive parts inside LCD module, and may cause scratches or dust on the display. IVO does not warrant the module, if customers disassemble or modify the module.
3. If LCD panel is broken and liquid crystal spills out, do not ingest or inhale liquid Crystal, and do not contact liquid crystal with skin. If liquid crystal contacts mouth or eyes, rinse out with water immediately. If liquid crystal contacts skin or cloths, wash it off immediately with alcohol and Rinse thoroughly with water.
4. Disconnect power supply before handling LCD module
5. Refrain from strong mechanical shock and /or any force to the module.
6. Do not exceed the absolute maximum rating values, such as the supply voltage variation, input voltage variation, variation in parts' parameters, environmental temperature; etc otherwise LCD module may be damaged. It's recommended employing protection circuit for power supply.
7. Do not touch, push or rub the polarizer with anything harder than HB pencil lead. Use fingerstalls of soft gloves in order to keep clean display quality, when Persons handle the LCD module for incoming inspection or assembly.
8. When the surface is dusty, please wipe gently with absorbent cotton or other soft Material. When cleaning the adhesives, please use absorbent cotton wetted with a little Petroleum benzene or other adequate solvent.
9. Wipe off saliva or water drops as soon as possible. If saliva or water drops Contact with polarizer for a long time, they may causes deformation or color Fading.
10. Protection film must remove very slowly from the surface of LCD module to Prevent from electrostatic occurrence.
11. Because LCD module uses CMOS-IC on circuit board and TFT-LCD panel, it is Very weak to electrostatic discharge, Please be careful with electrostatic Discharge .Persons who handle the module should be grounded through adequate methods.
12. Do not adjust the variable resistor located on the module.

► Storage Precaution

1. Please do not leave LCD module in the environment of high humidity and high temperature for a long time.
2. The module shall not be exposed under strong light such as direct sunlight. Otherwise, Display characteristics may be changed.
3. The module should be stored in a dark place. It is prohibited to apply sunlight or fluorescent light in storage.

▶ Operation Precaution

1. Do not connect or disconnect the module in the "Power On" condition.
2. Power supply should always be turned on/off by "Power on/off sequence"
3. Module has high frequency circuits. Sufficient suppression to the electromagnetic interference should be done by system manufacturers. Grounding and shielding methods may be important to minimize the interference.
4. After installation of the TFT Module into an enclosure, do not twist nor bend the TFT Module even momentary. At designing the enclosure, it should be taken into consideration that no bending/twisting forces are applied to the TFT Module from outside. Otherwise the TFT Module may be damaged.

▶ Others

1. Ultra-violet ray filter is necessary for outdoor operation.
2. Avoid condensation of water which may result in improper operation or disconnection of electrode.
3. If the module keeps displaying the same pattern for a long period of time, the image may be "sticked" to the screen.
4. This module has its circuitry PCB's on the rear side and should be handled carefully in order not to be stressed.

▶ Disposal

When disposing LCD module, obey the local environmental regulations.

Interface Board

- ▶ This interface board is for LCD Display and designed to fit 12.1"LCD Panel (receives the 6Bit LVDS signal and drives the LCD).

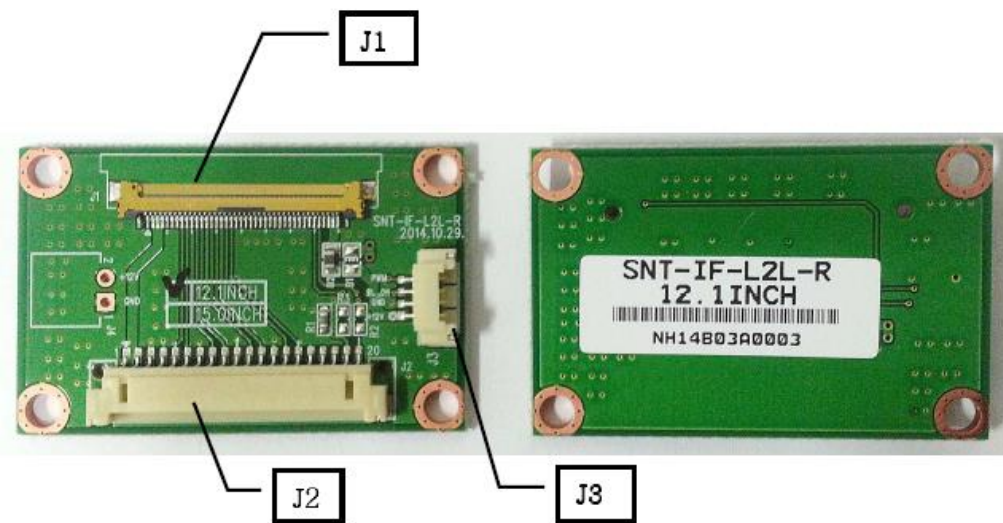
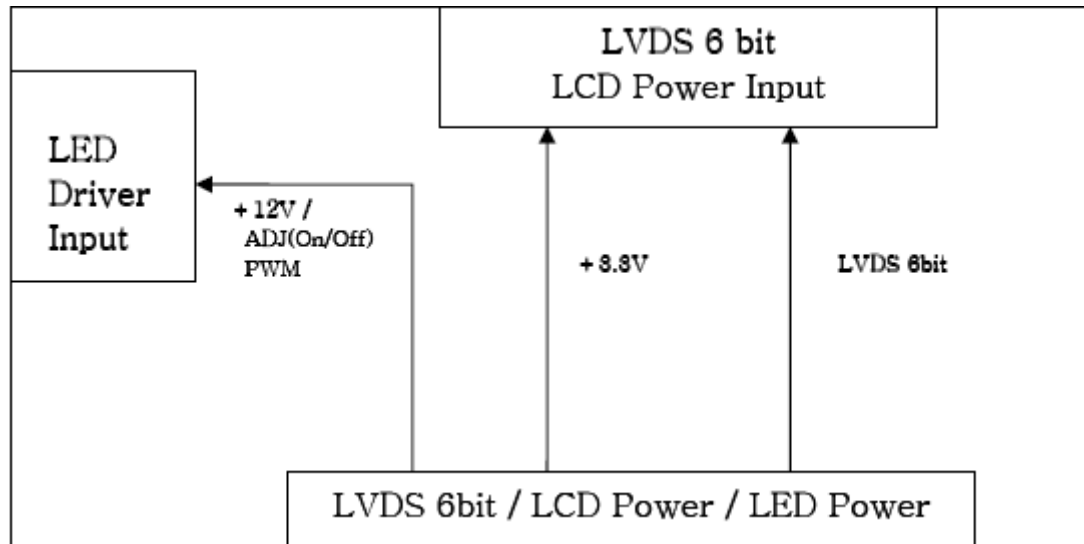

• Connector Information

| Name | Vender | Part Number | Location |
|----------|----------|---------------|----------|
| LVDS IN | LS Mtron | GT05Q-40S-H10 | J1 |
| LVDS OUT | YEONHO | 12507WR-20 | J2 |
| BL OUT | YEONHO | LAD1140-04 | J3 |

▶ Pin Assignment

1. Connector J1 [LS Mtron GT05Q-40S-H10]

| PIN No. | PIN Name | Function |
|---------|----------|---------------------------|
| 1 | N.C | Not Connector |
| 2 | VCC | +3.3V Power |
| 3 | VCC | +3.3V Power |
| 4 | VCC | +3.3V Power |
| 5 | N.C | Not Connector |
| 6 | N.C | Not Connector |
| 7 | N.C | Not Connector |
| 8 | RXIN0- | LVDS Signal(-) - Channel0 |
| 9 | RXIN0+ | LVDS Signal(+) - Channel0 |
| 10 | GND | Ground |
| 11 | RXIN1- | LVDS Signal(-) - Channel1 |
| 12 | RXIN1+ | LVDS Signal(+) - Channel1 |
| 13 | GND | Ground |
| 14 | RXIN2- | LVDS Signal(-) - Channel2 |
| 15 | RXIN2+ | LVDS Signal(+) - Channel2 |
| 16 | GND | Ground |
| 17 | RXCLKIN- | LVDS Clock Signal(-) |
| 18 | RXCLKIN+ | LVDS Clock Signal(+) |
| 19 | GND | Ground |
| 20 | N.C | Not Connector |
| 21 | N.C | Not Connector |
| 22 | GND | Ground |
| 23 | N.C | Not Connector |
| 24 | N.C | Not Connector |
| 25 | GND | Ground |
| 26 | N.C | Not Connector |
| 27 | N.C | Not Connector |
| 28 | GND | Ground |
| 29 | N.C | Not Connector |
| 30 | N.C | Not Connector |
| 31 | VSSLED | Ground - LED |
| 32 | VSSLED | Ground - LED |
| 33 | VSSLED | Ground - LED |
| 34 | N.C | Not Connector |
| 35 | PWM | System PWM Signal Input |
| 36 | LED_EN | LED Enable |
| 37 | N.C | Not Connector |
| 38 | VLED | Power Supply for LED |
| 39 | VLED | Power Supply for LED |
| 40 | VLED | Power Supply for LED |

2. Connector J2 [Yeonho 12507WR-20]

| PIN No. | PIN Name | Function | Remark |
|---------|----------|---------------------------|--------------------|
| 1 | VDD | +3.3V Power | |
| 2 | VDD | +3.3V Power | |
| 3 | VSS | Ground | |
| 4 | REV | Reverse Scan selection | Low |
| 5 | RIN1- | LVDS Signal(-) - Channel1 | |
| 6 | RIN1+ | LVDS Signal(+) - Channel1 | |
| 7 | VSS | Ground | |
| 8 | RIN2- | LVDS Signal(-) - Channel2 | |
| 9 | RIN2+ | LVDS Signal(+) - Channel2 | |
| 10 | VSS | Ground | |
| 11 | RIN3- | LVDS Signal(-) - Channel3 | |
| 12 | RIN3+ | LVDS Signal(+) - Channel3 | |
| 13 | VSS | Ground | |
| 14 | CLKIN- | LVDS Clock Signal(-) | |
| 15 | CLKIN+ | LVDS Clock Signal(+) | |
| 16 | GND | Ground | |
| 17 | RIN4- | LVDS Signal(-) - Channel4 | |
| 18 | RIN4+ | LVDS Signal(+) - Channel4 | |
| 19 | SEL6/8 | 6/8bit LVDS Selection | H:8bit / L:nc:6bit |
| 20 | Bist | Not Connector | Internal use |

3. Connector J3 [Yeonho 12505WR-04]

|  | PIN No. | PIN Name | Function | Remark |
|---|---------|----------|--------------|----------------|
| | 1 | Vcc | +12.0V Power | |
| | 2 | GND | Ground | |
| | 3 | On/Off | On/Off | 5V:On / 0V:Off |
| | 4 | Dimming | PWM | |

Touch Function Key

- ▶ H/W configuration
 1. Configured on the left and right symmetrically.
 2. Using GT108L(Green Chip) Touch Sensor, recognize the 4CH touch (multi-touch -> unable)
 3. When power is connected, LED of 4Ch is on.
When touched, LED of the Ch for that is off.
 4. Board Layout



. Touch Function Key Right



. Touch Function Key Left

5. Block Diagram

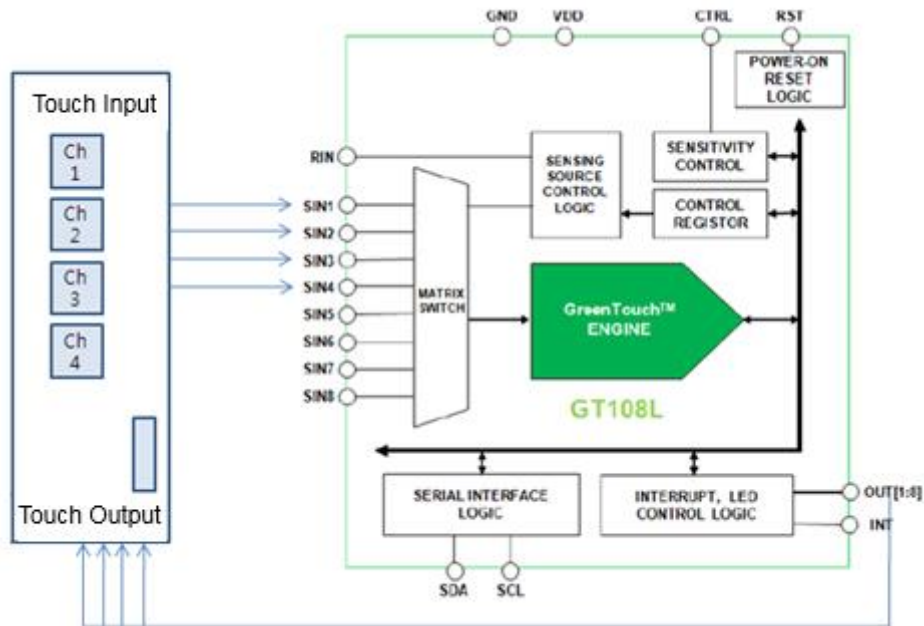

▶ External Interface Connector

| CN1 3330000044 CONN:HDR:R/A:6P:S06B-XASK-JST | | | |
|---|-------------|-----|-------------|
| Pin | Description | Pin | Description |
| 1 | GND | 4 | OUT_C |
| 2 | OUT_A | 5 | OUT_D |
| 3 | OUT_B | 6 | +5V |

Modem Board

► This board is composed of Silicon Laboratories' ISOModem and Integrated DAA. The ISOModem® family of products is a complete modem ranging in speed from 56,000 bps to 2400 bps. Offered as a chipset with the Si2457 system-side device and the Si3018 line-side device, the ISOModem utilizes Silicon Laboratories' patented direct access arrangement (DAA) technology to provide a programmable telephone line interface with an unparalleled level of integration. These compact solutions eliminate the need for a separate DSP, modem controller, codec, transformer, relay, opto-isolators, clocking crystal, and 2-4 wire hybrid. The device is ideal for embedded modem applications due to their flexibility, small footprint, and minimal external component count.

► Features

1. Data modem formats
2. ITU-T, Bell
3. 300 bps up to 56 kbps
4. V.21, V.22, V.29 Fast Connect
5. V.42, V.42bis, MNP2-5
6. Automatic rate negotiation
7. Type I and II caller ID decode
8. UART interface
9. AT command set support
10. SMS / MMS support
11. Integrated DAA
 - Over 6000 V Capacitive isolation
 - Parallel phone detect
 - Globally-compliant line interface
12. 27 MHz clock input
13. Single 3.3 V power supply
14. Firmware upgradeable
15. EEPROM interface
16. Pb-free, RoHS Compliant

► Block Diagram

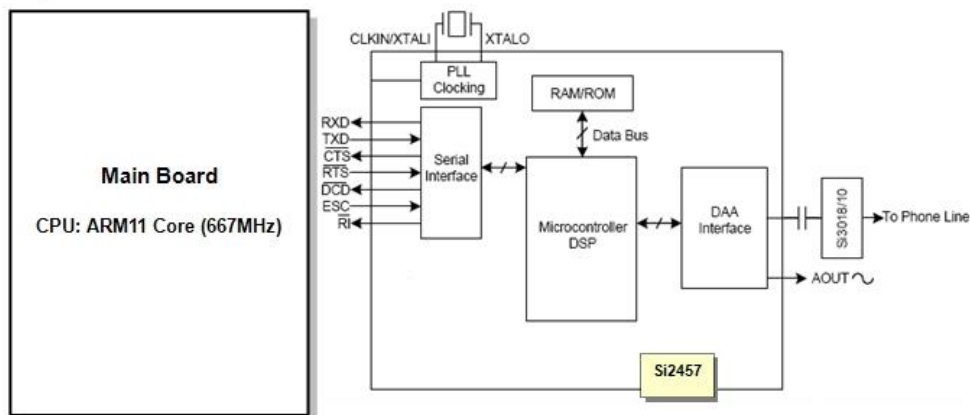

▶ Pin Assign

| | | |
|------|---|-------------------|
| CN24 | 1 | +3V3 |
| | 2 | +3V3 |
| | 3 | GND |
| | 4 | GND |
| | 5 | LnRESET |
| | 6 | MODEM_nCD |
| | 7 | MODEM_nDSR |
| | 8 | M_SPKO(Sound Out) |
| CN25 | 1 | MODEM_nRTS |
| | 2 | MODEM_RXD |
| | 3 | MODEM_TXD |
| | 4 | MODEM_nRI |
| | 5 | MODEM_nDTR |
| | 6 | MODEM_nCTS |
| | 7 | GND |

Cortex Mainboard

Basic Specification

| Item | | Specification | | Remarks (Option) |
|--|-------------------|-------------------------|------|---|
| Main Controller | CPU | Samsung S5PV210 | | 1 GHz |
| | Operating System | Windows Embedded CE 6.0 | | |
| Memory | DDR2 | 512MB | | 128MB X 4EA (32Bit Interface) |
| | NAND Flash | 256MB | | 8bit Interface |
| Clock | PLL, MPLL, EPLL | 24MHz | | |
| | USB | 24MHz | | |
| | DAC/HDMI | 27MHz | | |
| | RTC | 32.768kHz | | |
| JTAG | JTAG | 1 EA | | |
| RESET | PMIC | MAX8698CEWO | | 2.61V monitoring / 60ms |
| POWER | Input | 3.3V | | |
| | Output | 1.8V | PMIC | For MEM, MIPI I/O, |
| | | 1.1V | PMIC | For INT, ALIVE, HDMI |
| | | 1.2V | PMIC | For PLL |
| | | 1.25V | PMIC | For ARM |
| | | 3.0V | PMIC | For CAM, RTC |
| | | 3.3V | PMIC | For NAND, ETC |
| Jumper | Resistance Jumper | 1 bit | | Boot mode select |
| Battery | Coin Battery | CR2032 Type | | For RTC |
| Interface (Supported through I/O Board) | Serial Ports | 4 Ports | | On chip considered only. |
| | USB Ports | 1 Ports | | 1.1 Host (compatibility maintained) 2.0 Device |
| | MMC | 1 Port | | SD Card |
| | MODEM | 1 Port | | |
| | SPI | 1 Port | | |
| | LCD | RGB | | RGB 16bit |
| | | HDMI | | LVDS |
| | AC97 | 1 EA | | |
| | GPIO | 4 bit | | |
| | PWM | 1 Port | | |
| | I2C I/F | 1EA | | Vibration motor |
| Camera I/F | ITU R BT-656 | | | |
| Dimension | Dimension | 100 X 75 | | mm |

CPU Block Diagram

► CPU Block Diagram

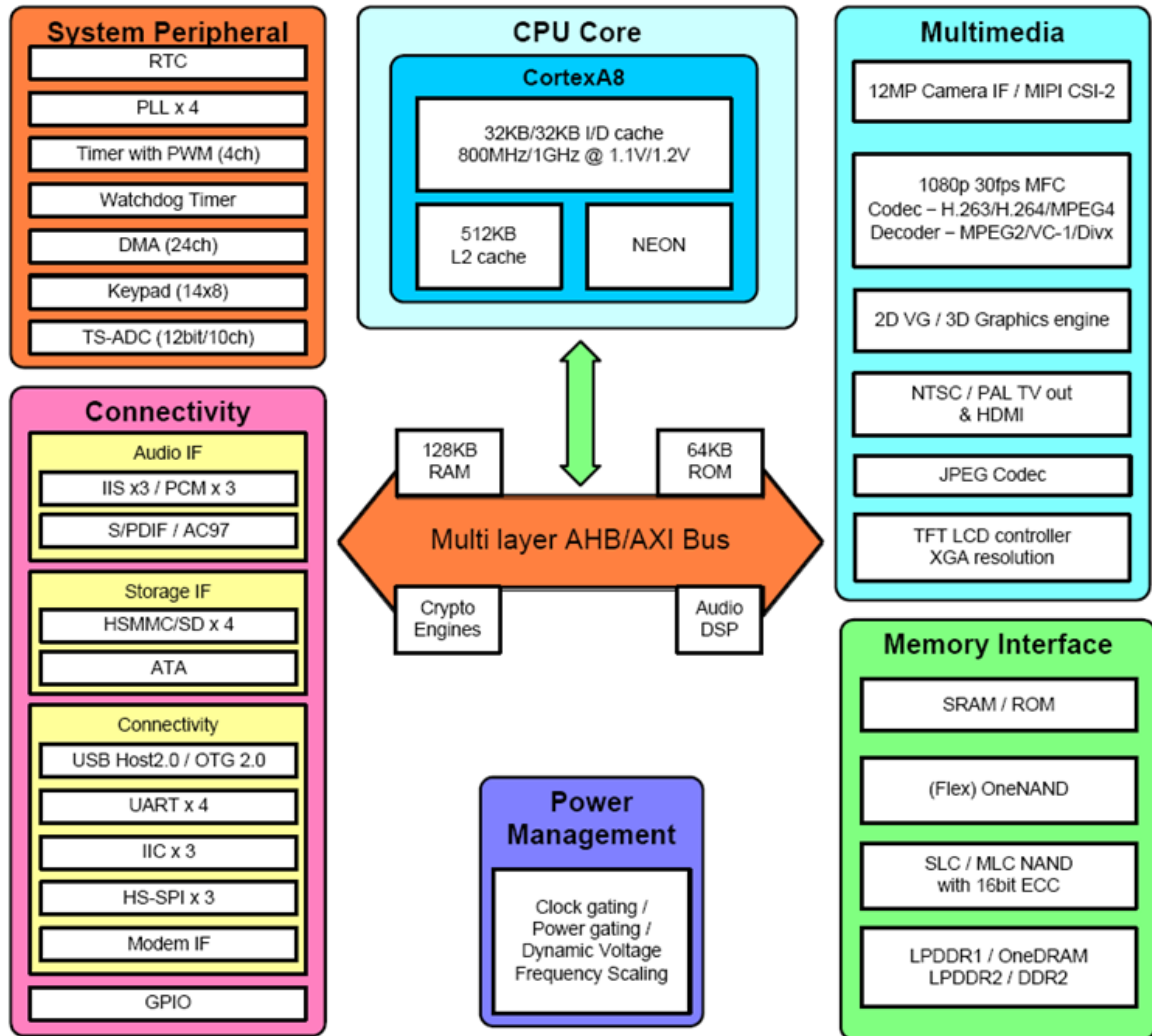

Board Block Diagram

► Board Block Diagram

CORTEX-A8(S5PV210) M/B BLOCK DIAGRAM

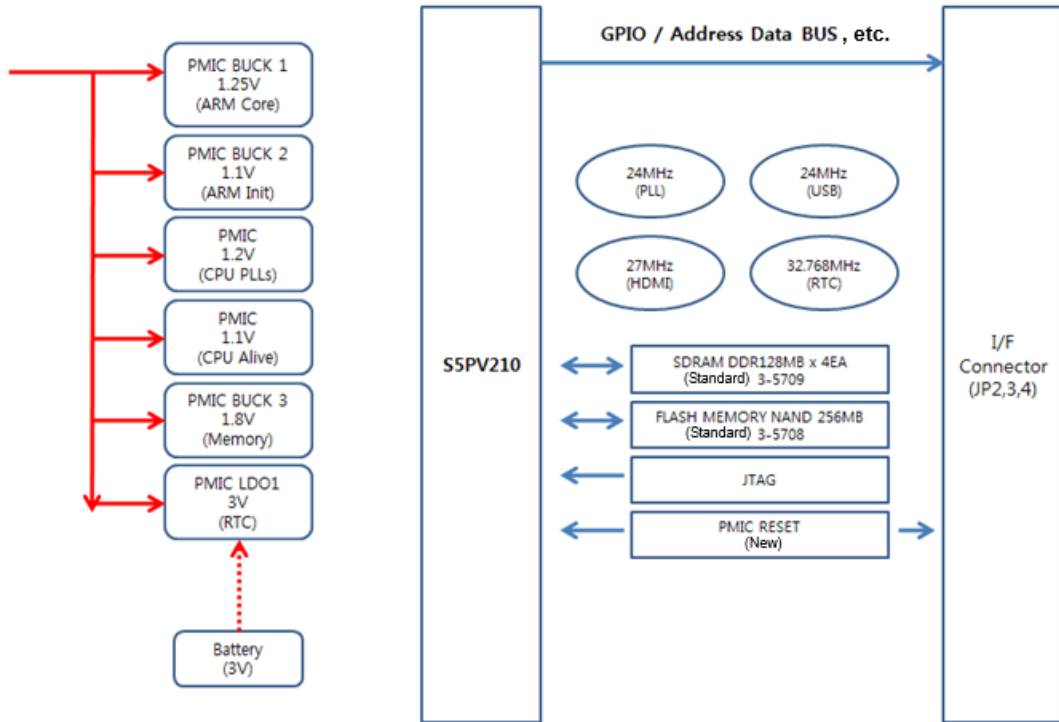

Board Layout

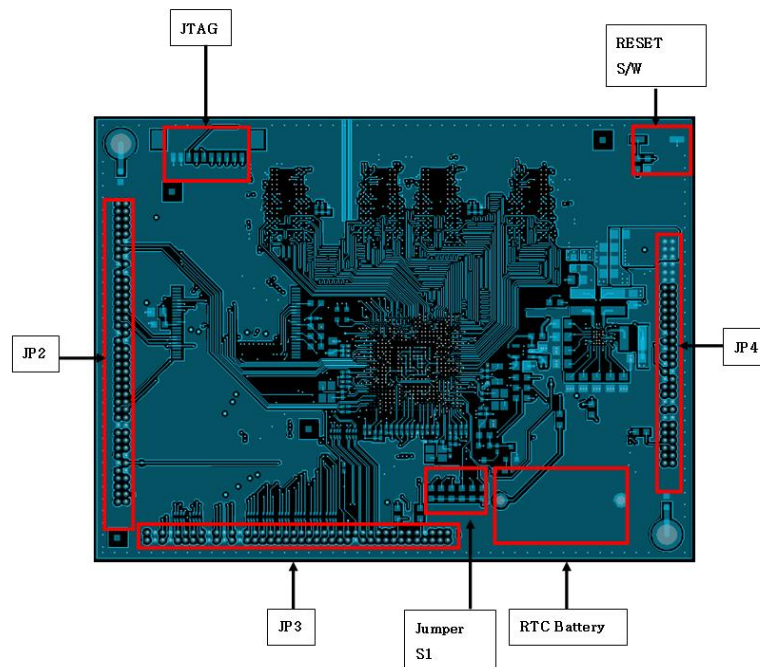

Mini HUB Board

▶ Mini HUB Board

1. NEC 4PORT USB MINI HUB B/D

2. Specification

1) Main Chipset

- USB HUB Controller : uPD720114, 40pin (RENESAS)
- Clock Input : 30MHz (SUNNY)
- Power Distribution Switch : MIC2026A (MICREL)

2) Reset Logic : DS1818 Chip applied

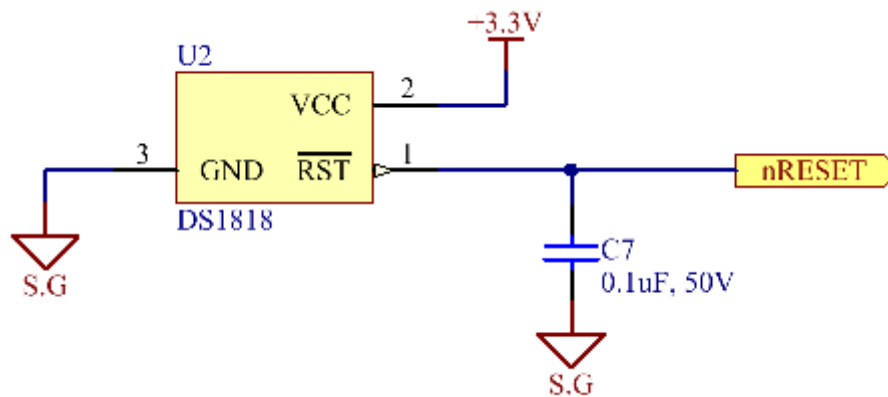

3) USB Input/output Port

- Host : USB B type (292304-1, R/A), 1 Port
- Device : USB A type (787616-1, R/A), 4 Port

4) Power Configuration

- Input Voltage : DC 5V \pm 5% (4.75~5.25V)
 - : +3.3V Reg. IC Input Power & USB Vbus power supported
- Inner Voltage: DC 3.3V
 - : LM1117MPX-3.3V (Load Regulation \pm 0.4%, Line Regulation \pm 0.4%)
 - : uPD720114 Controller power supported

5) Individual Overcurrent Detection supported

- Operated when more than 500mA per device port used.

3. Block Diagram

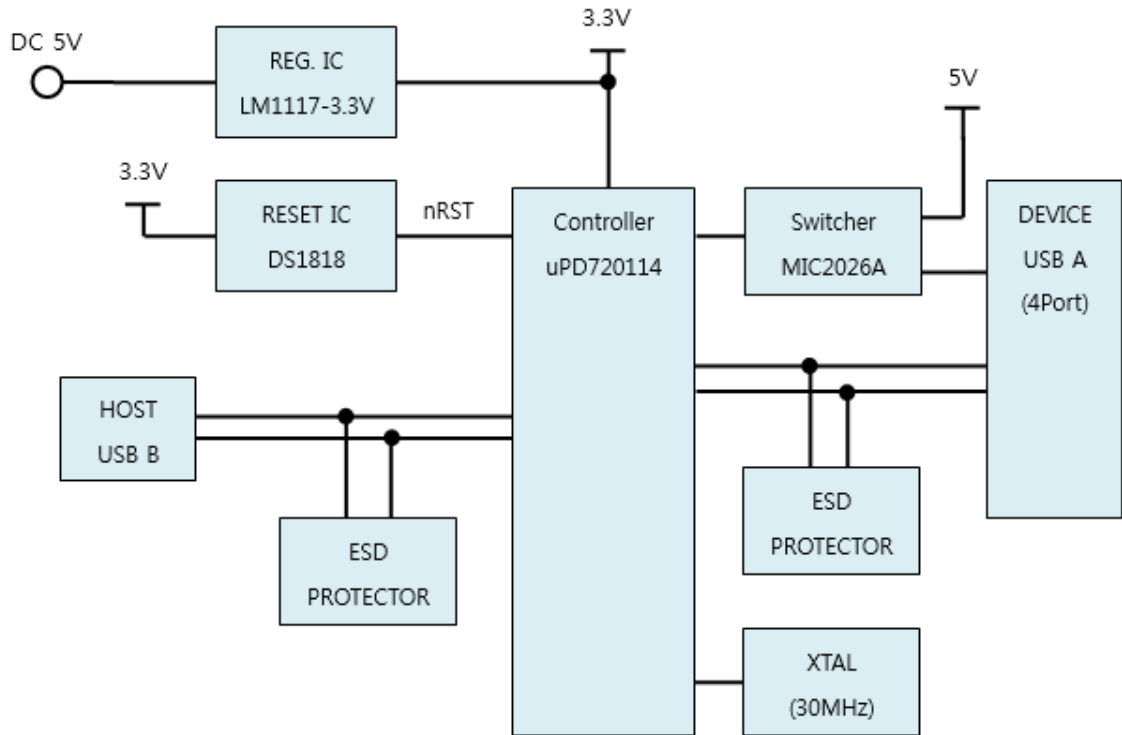

4. Component Layout

1) Top Side

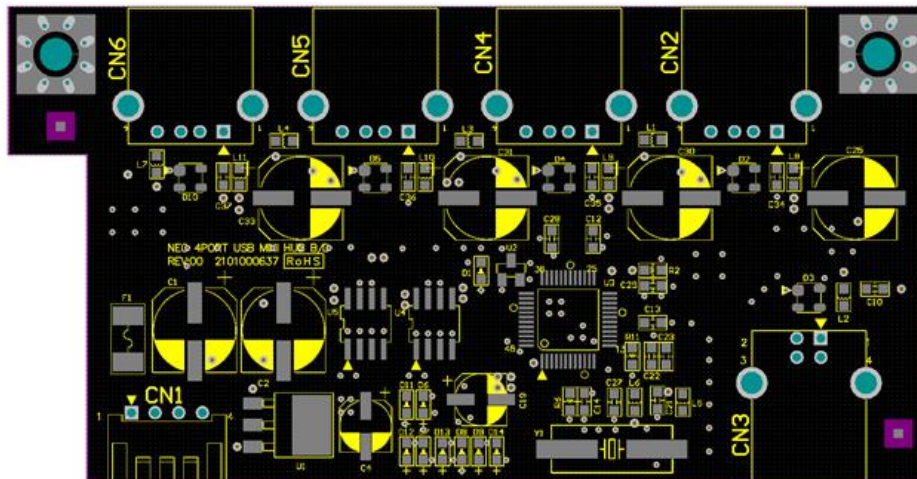

2) Bottom Side

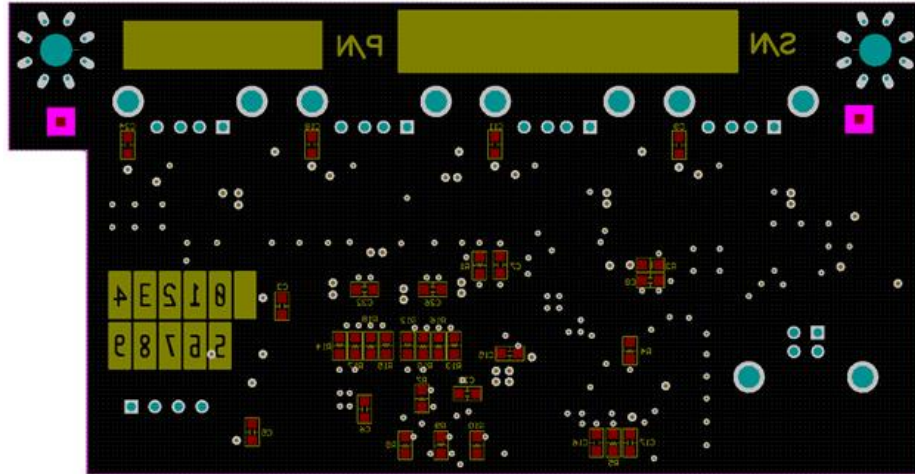

5. External Interface Connector

1) Input Power (CN1)

| PIN No. | Description | Remark |
|---------|-------------|-----------------------------|
| 1 | +5V | SMAW250-04P (3330000279) |
| 2 | +5V | |
| 3 | GND | |
| 4 | GND | |

2) Host (CN3)

| PIN No. | Description | Remark |
|---------|-------------|--------------------------|
| 1 | +5V | USB B type (33373601) |
| 2 | D- | |
| 3 | D+ | |
| 4 | GND | |

3) Device (CN2, CN4, CN5, CN6)

| PIN No. | Description | Remark |
|---------|-------------|--------------------------|
| 1 | +5V | USB A Type (33373501) |
| 2 | D- | |
| 3 | D+ | |
| 4 | GND | |

Encryption PIN Pad

- ▶ EPP (Encrypted PIN Pad) is a device that encrypts sensitive data such as customers' card information and passwords, which requires the highest level of security, and transmits it to the Host. Therefore, if EPP problem occurs in the field, verify the problem and replace the entire unit. You cannot disassemble the internal components or replace them individually.

The following figure is the back of the EPP. The functions and roles of each part are summarized as below.

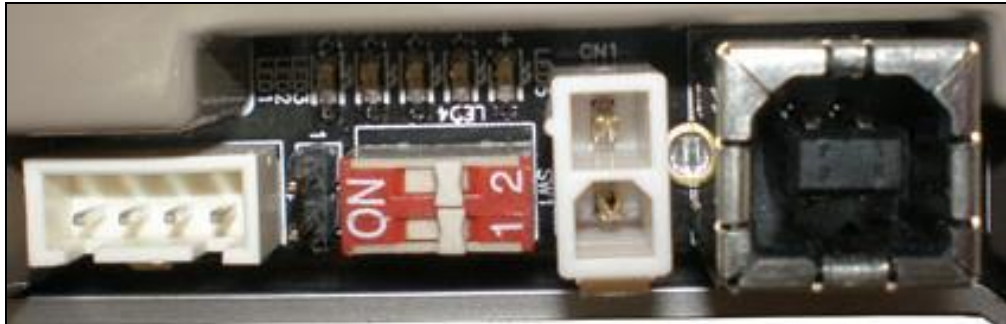

| No | Label | Setting | Description | Remarks |
|----|-------|-----------|--|-----------------------|
| 1 | LED1 | Red | Serial Reception RX | Common for USB/Serial |
| 2 | LED2 | Green | Serial Transmission TX | Common for USB/Serial |
| 3 | LED3 | Red | Flickering at one-second intervals during normal operation of EP | Common for USB/Serial |
| 4 | LED4 | Red | NVRAM CLEAR | Common for USB/Serial |
| 5 | LED5 | Green | Power LED | Common for USB/Serial |
| 6 | SW1 | No. 1 OFF | NVRAM CLEAR during ON | Common for USB/Serial |
| | | No. 2 OFF | USB Communication during ON Serial Communication during OFF | Common for USB/Serial |
| 7 | J2 | OPEN | Boot firmware download is available for CLOSE. | Common for USB/Serial |
| 8 | CN1 | - | Power Connector | Common for USB/Serial |
| 9 | CN2 | - | Serial Connector | Common for USB/Serial |
| 10 | CN10 | - | USB Connector | Common for USB/Serial |

Common Occurred Problem List

- ▶ Common Occurred Problem List
 1. In case the EPP cover is detached-- to whatever extent-- due to a mistake made by an operator or the maintenance personnel
 2. In case there is a damage caused by any external shock or static electricity
 3. In case the EPP is not connected with an earth cable, which makes it vulnerable to static electricity
 4. In case the battery is discharged

Troubleshooting

- ▶ Since the problem in this unit involves a security issue, you should replace the entire unit when encountering a problem.
If a problem is confirmed, turn off the power, remove the power cable and bracket, and then replace the unit with a new one. For the assembly of the unit, follow the reverse order.
 1. If LED1 is off, check the cable connection to see if the power supply is okay.
 2. If LED1 is on and LED2 is off, it means EPP is in abnormal operation. Therefore, replace the EPP.

Contents

General Description and Scope..... 4-1

Input Electrical Specifications 4-1

 AC Input..... 4-1

 Inrush Current..... 4-1

 Input Line Current & Power Factor (P.F.)..... 4-1

 Efficiency 4-2

Output Electrical Requirements..... 4-2

 Output Voltage and Current Rating 4-2

 Load Capacity Specifications 4-3

 +24V Load for Test Temperature 4-3

 S+5V Signal Specification 4-3

 Apply Extra Outlet 4-4

 Hold-Up Time (@Fullload of “Loading Table for Efficiency Measurements”) 4-4

 Output Rise Time..... 4-4

 Over Voltage Protection 4-4

 Short Circuit Protection 4-4

Environmental Requirement 4-5

 Temperature Range..... 4-5

 Humidity..... 4-5

 Vibration 4-5

 Ground Leakage Current..... 4-5

 Reliability 4-5

 Dielectric Strength 4-6

 Insulation Resistance 4-6

General Description and Scope

- ▶ AC-line powered switching power supply with active PFC (Power Factor Correction) circuit, meet EN61000-3-2 and with Full Range Input features.
The specification below is intended to describe as detailedly as possible the functions and performance of the subject power supply.

Input Electrical Specifications

AC Input

<Note!>

Nominal voltages for test purposes are considered to be within $\pm 1.0V$ of nominal.

| Parameter | Min. | Nom.P ⁽¹⁾ | Max. | Unit |
|---------------------------|------|----------------------|------|--------------------|
| V _{in} (115VAC) | 90 | 110 | 150 | VAC _{rms} |
| V _{in} (230VAC) | 150 | 220 | 264 | VAC _{rms} |
| V _{in} Frequency | 47 | -- | 63 | HZ |

Inrush Current

- ▶ Inrush current shall be less than 70A
Maximum inrush current from power-on (with power on at any point on the AC sine) and including, but not limited to, three line cycles, shall be limited to a level below the surgerating of the input line cord, AC switch if present, bridge rectifier, fuse, and EMI filter components. Repetitive ON/OFF cycling of the AC input voltage should not damage the power supply or cause the input fuse to blow.

Input Line Current & Power Factor (P.F.)

- ▶ At Full load

| AC input | Input line current | P.F.@ Full Load | P.F.@ Pin=75W |
|----------|--------------------|-----------------|---------------|
| 110V | < 1.5Amps –rms | > 0.95 | > 0.9 |
| 220V | < 1Amps –rms | > 0.9 | > 0.85 |

Efficiency

► General

Under the load conditions defined in Tables below. The loading condition for testing efficiency shown in "Loading Table for Efficiency Measurements" represents a fully loaded system.

► Loading Table for Efficiency Measurements

| 100W (loading shown in Amps) | | | |
|------------------------------|------|------|------|
| Loading | +24V | +12V | +5V |
| Full | 3 A | 1.5A | 1.1A |

► Minimum Efficiency Vs Load

| Loading | Voltage | Full load |
|-----------------------------|---------|-----------|
| Required Minimum Efficiency | 110V | 85% |
| Required Minimum Efficiency | 220V | 86% |

Output Electrical Requirements

Output Voltage and Current Rating

| Output | MINIMUM LOAD | NORMAL LOAD | MAXIMUM LOAD | PEAK LOAD | LOAD REG | LINE REG. | RIPPLE | NOISE |
|--------|--------------|-------------|--------------|-----------|----------|-----------|----------|----------|
| +24V | 0A | 1.5A | 3A | 15A | ±10% | ±1% | 240mVp-p | 500mVp-p |
| +12V | 0A | 0.75A | 1.5A | | ±5% | ±1% | 120mVp-p | 300mVp-p |
| +5V | 0A | 1.5A | 3A | 3.5A | ±5% | ±1% | 50mVp-p | 100mVp-p |

1. +5V & +12V total output not exceed 23.5W.
2. Voltages and ripple are measured at the load side of mating connectors with a 0.1 uF onolithic ceramic capacitor paralleled by a 10 uF electrolytic capacitor across the measuring terminals.
3. RIPPLE & NOISE test condition : Bandwidth 20MHz
4. +24V PEAK LOAD time does not exceed 0.5mS

Load Capacity Specifications

- ▶ The cross regulation defined as follows, the voltage regulation limits DC include DC Output ripple & noise.

| LOAD | +24V | +12V | +5V |
|-------------|------|------|------|
| condition_1 | 0A | 0A | 0A |
| condition_2 | 0A | 0A | 3A |
| condition_3 | 0A | 1.5A | 0A |
| condition_4 | 3A | 0A | 0A |
| condition_5 | 3A | 1.5A | 1.1A |
| condition_6 | 3A | 0.7A | 3A |

+24V Load for Test Temperature

- ▶ +24VLOAD FOR TESTTEMPERATURE (+12V & +5V @Fullload of “Loading Table for Efficiency Measurements”)

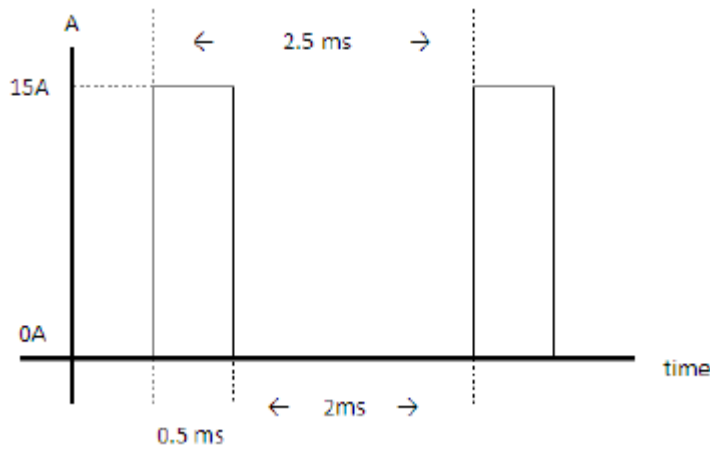

S+5V Signal Specification

- ▶ +5V Signal Specification (@Full load of “Loading Table for Efficiency Measurements”)

VAC : 110V

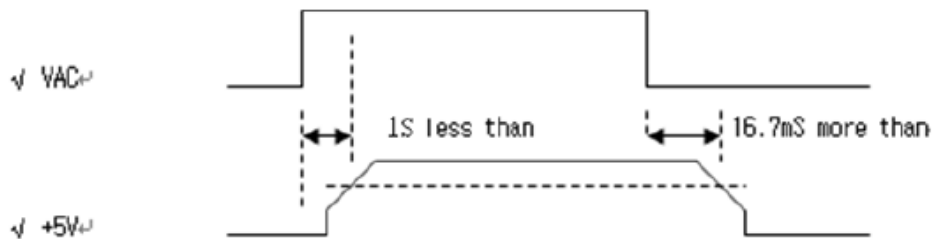

Apply Extra Outlet

- ▶ 100Vac ~ 240Vac / 1.0A Max

Hold-Up Time (@Fullload of “Loading Table for Efficiency Measurements”)

- ▶ 110V / 60Hz : 20msec.minimum.
220V / 50Hz : 20msec.minimum.

The output voltage will remain within specification, in the event that the input power is removed or interrupted, for the duration of one cycle of the input frequency. The interruption may occur at any point in the AC voltage cycle. The power good signal shall remain high during this test.

Output Rise Time

- ▶ (10% TO 90% OF FINAL OUTPUT VALUE, @FULL LOAD)
115V-rmsor230V-rms
+ 5Vdc: 20ms Maximum
+ 12Vdc:20msMaximum
+24Vdc : 20msMaximum

Over Voltage Protection

| Voltage Source | Protection Point |
|----------------|------------------|
| +5V | 5.6V-7.5V |
| +12V | 13.3V-15.6V |
| +24V | 26.5V-31.2V |

Short Circuit Protection

- ▶ Output short circuit is defined to be a short circuit load of less than 0.1 ohm.

In the event of an output short circuit condition on +5V, +12V or +24V output, the power supply will shut down and latch off without damage to the power supply. The power supply shall return to normal operation after the short circuit has been removed and the power switch has been turned off for no more than 5 seconds.

Environmental Requirement

- ▶ The power supply will be compliant with each item in this specification for the following Environmental conditions.

Temperature Range

| | |
|-----------|------------------|
| Operating | -10to +60deg. C |
| Storage | -20 to +75deg. C |

Humidity

| | |
|-----------|---------------------------|
| Operating | 20–90% RH, Non-condensing |
| Storage | 20–90% RH, Non-condensing |

Vibration

- ▶ The subject power supply will withstand the following imposed conditions without experiencing non-recoverable failure or deviation from specified output characteristics.
Vibration Operating –Sine wave excited, 0.5G maximum acceleration, 10-250 Hz swept at one octave / min. Fifteen minute dwell at all resonant points, where resonance is defined as those exciting frequencies at which the device under test experiences excursions two times large than non-resonant excursions.
Plane of vibration to be along three mutually perpendicular axes.

Ground Leakage Current

- ▶ The power supply ground leakage current shall be less than 3.5mA.

Reliability

- ▶ The power supply reliability, when calculated by MIL-HDBK-217;latest revision, are exceed 300,000 hours with all output at Typical load and an ambient temperature of 25°C .

Dielectric Strength

| Division | Test Point | Test Input Voltage | Test Condition |
|----------------------|------------|--------------------|--|
| Withstanding Voltage | PRI –SEC | AC 3000V | DURING OF TEST: 1 minute CUTOFF CURRENT: 10mA |
| | PRI -F.G | AC 1800V | |

Insulation Resistance

| Division | Test Point | Test Input Voltage | Test Condition |
|-----------------------|------------|--------------------|---|
| Insulation Resistance | PRI –SEC | DC 500V | During Of Test: 1 minute Insulation RES: ≥10Mohm |
| | PRI -F.G | DC 500V | |

Contents

CDU-L3..... 5-1

- Overview..... 5-1
- Disassembly & Reassembly..... 5-4
 - Module Disassembly..... 5-4
 - Electronic Parts Disassembly..... 5-6
 - Sensor Disassembly..... 5-6
 - Motor Disassembly..... 5-12
 - Solenoid Disassembly..... 5-13
 - Clutch Disassembly..... 5-15
 - PCBA Disassembly..... 5-17
- Preventive Maintenance..... 5-18
 - Lubrication..... 5-18
 - Lubrication Standard..... 5-18
 - Lubrication Standard for each part..... 5-19
 - Cleaning (Inspection)..... 5-20
 - Overview of Cleaning Standard..... 5-20
 - Cleaning Cycle..... 5-20
 - Cleaning Point and Method..... 5-20
- Parts Replacement..... 5-22
 - Required Tools for Replacement..... 5-22
 - How to Replace..... 5-23
- Troubleshooting..... 5-24

CDU-M..... 5-25

- Appearance/Functional Diagram..... 5-25
- Cassette..... 5-26
- Actuator Diagram..... 5-27
- Sensor Diagram..... 5-28
- Module and Sensor Replacement..... 5-29
 - Sensor Replacement..... 5-29
 - Module Replacement..... 5-42
- Adjustment Standard..... 5-47
- Oiling Standard..... 5-49
- Cleaning Standard..... 5-50
- Setting Specifications..... 5-51
- Cable Connection Diagram..... 5-52

CDU21..... 5-53

- Overview..... 5-53
- Disassembly & Reassembly..... 5-56
 - Module Disassembly..... 5-56
 - Electronic Parts Disassembly..... 5-61
 - PCBA Disassembly..... 5-61
 - Sensor Disassembly..... 5-63

| | |
|--------------------------------|------|
| Actuator Disassembly | 5-72 |
| Oiling Standard | 5-77 |
| Cleaning Standard | 5-78 |
| Setting Specifications | 5-79 |
| Cable Connection Diagram | 5-80 |

CDU-L3

Overview

▶ Appearance & Dimension

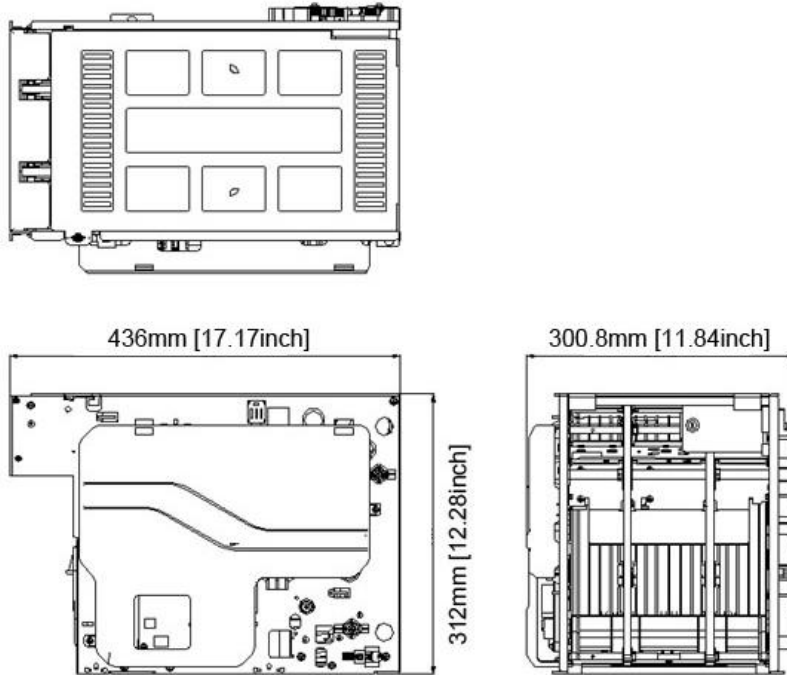

► Device Configuration

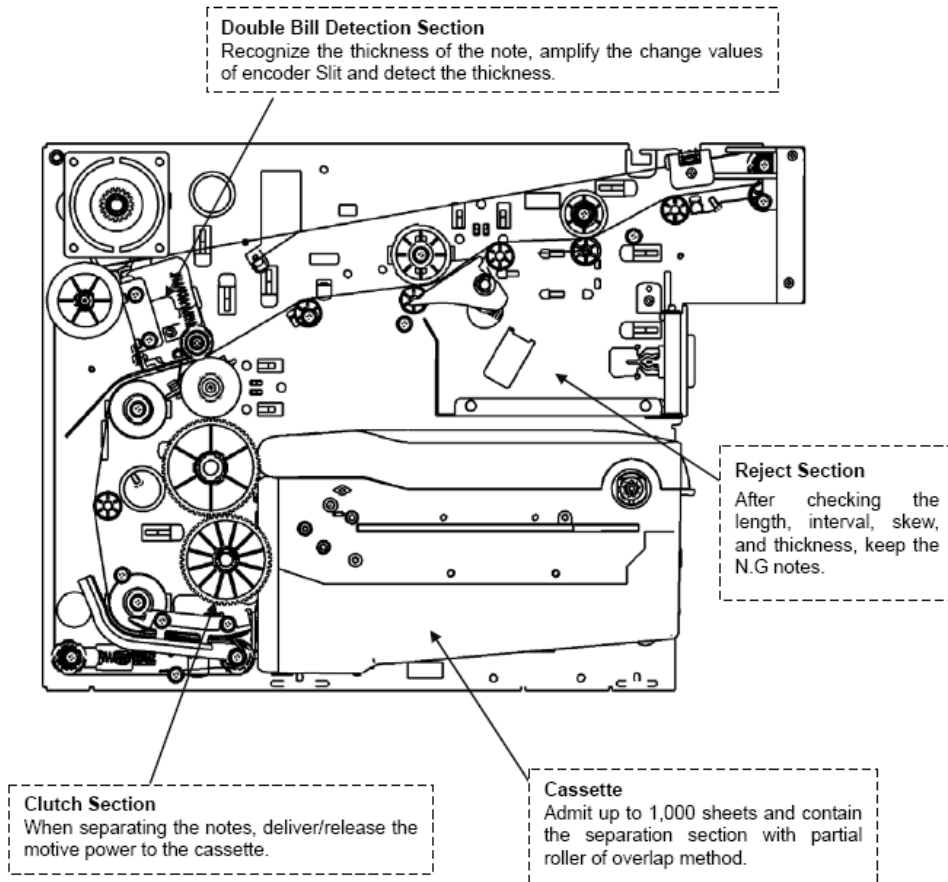

► Device Configuration Module

| Module | Description |
|-------------------------------|---|
| Clutch Section | When dispensing the notes, deliver the motive power to the cassette to separate the notes. Then after separation, release the motive power. |
| Double Bill Detection Section | Detect the thickness of the separated note and if it is more than 2 sheets, obtain the data to make the notes rejected. |
| Cassette Section | Admit up to 1,000 sheets and contain the separation section (partial roller structure of overlap method). |
| Reject Section | After checking the length, interval, skew, and thickness of the separated notes, keep the N.G notes. |

► Specification

| Item | | Specification | Remarks |
|---------------------|-------------------------|--|----------------------------|
| External Appearance | Dimension (mm) | 300.8(W)x312(H)x436(D)mm (11.84x12.28x17.17inch) | |
| Weight | Weight of the main body | 10Kg (22.05lb) | |
| | Weight of the cassette | Empty(2.37Kg (5.22lb)) / Full(1,000sheets) status (3.3Kg (7.28lb)) | |
| Media | Denomination | USA/Canadian Dollar | |
| | Media Size (LxH) | USA (156x66mm (6.14x2.6inch)) / Canada (152.4x70mm (6x2.76inch)) | |
| | Thickness | 0.09 ~ 0.11mm (0.0035~0.0043inch) | |
| Dispensing | Shutter Yes/No | No | Tray outside the main body |
| | Dispensing Speed | 4 sheets/sec | |
| | Maximum number | 40 sheets/transaction | |
| Separation | Separation Type | Friction Type | |
| Reject | Capacity | 200sheets | Based on new notes |
| | Security | No Key | |
| | Quantity Detection | No | Software Count |
| Cassette | Capacity | 1,000sheets | Based on new notes |
| | Loading Direction | Front Access | Front Access Type |
| | Detecting Remnants | No | |

Disassembly & Reassembly

Module Disassembly

► Disassembly of Double Bill Detection Section

1. Remove 2 screws (①) and disassemble Main Cover (②).
2. Disassemble cable connector CS5/M1.
3. Remove 3 screws (③) and disassemble ASSY MOTOR (④).
4. Remove 2 screws (⑤) and disassemble Shaft Reinforce (⑥).

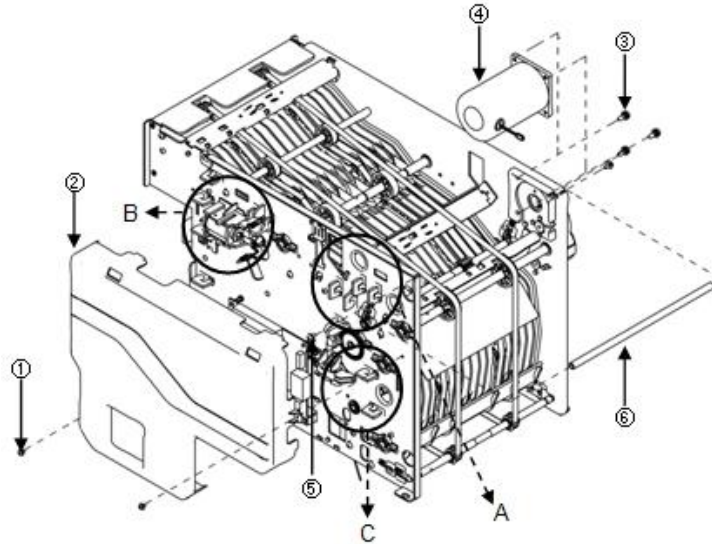

5. Remove 2 screws (⑦) and disassemble ASSY PULLEY_ID (⑧).
6. Remove 2 screws (⑨) and disassemble ASSY PULLEY_DR (⑩).
7. Remove 1 screw (⑪) and disassemble GEAR Z36W08M10_DR (⑫).
8. Disassemble ASSY GEAR Z28W09M10_ID (⑬).

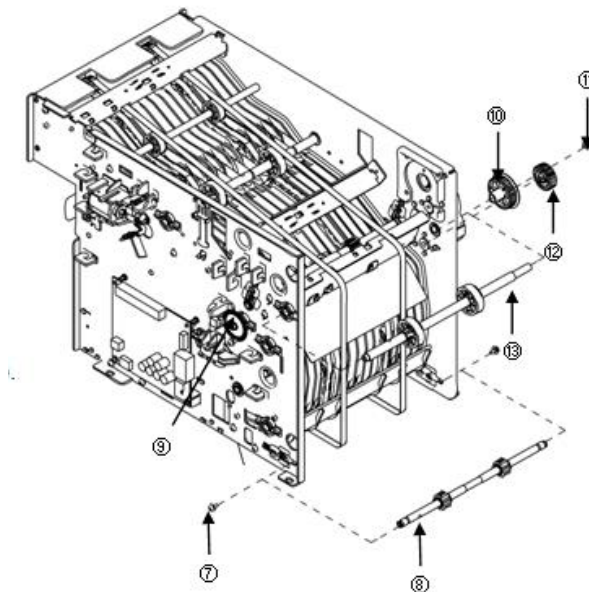

9. Remove 4 screws (⑭) and disassemble Double Bill Detection Section (⑮).
10. To assemble again, use the reverse order of disassembling.

<Note!> Be sure to insert the belt during assembling ASSY PULLEY and Double Bill Detection Section.

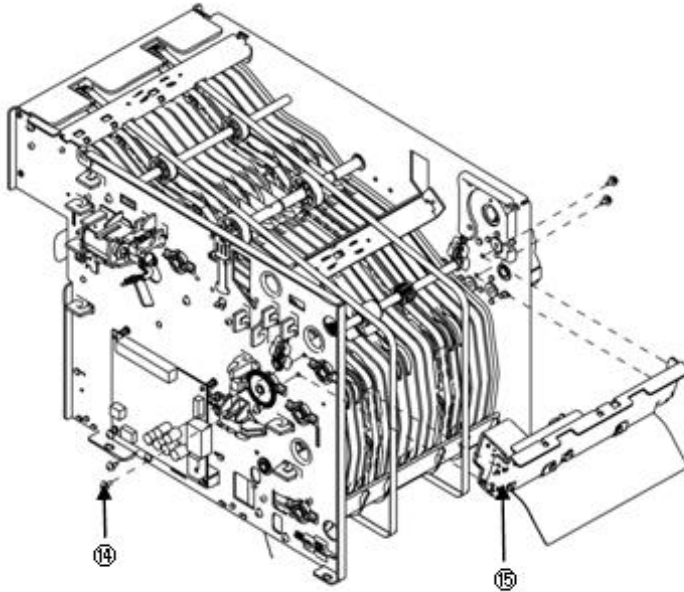

Electronic Parts Disassembly

Sensor Disassembly

▶ Location Map of Sensor

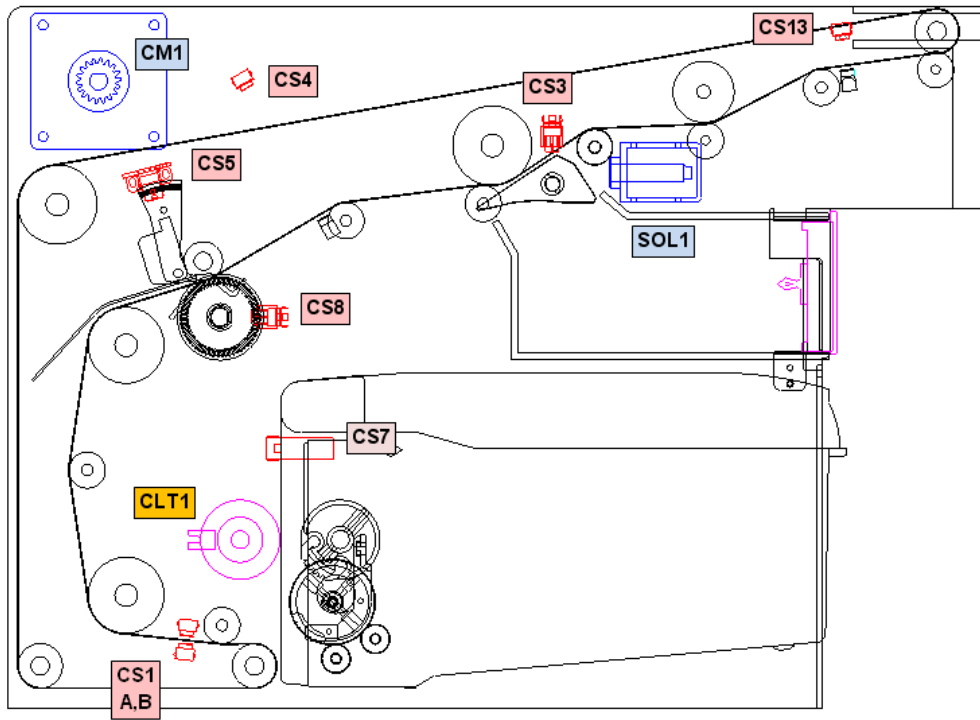

► Disassembly of Integrated Sensor

1) CS13

1. Disassemble main cover. (Refer to No.1 of “Disassembly of Double Bill Detection Section”)
2. Disassemble CABLE (CS13) (Section B on figure of “Disassembly of Double Bill Detection Section”)
3. Remove 2 screws (①) and disassemble Sensor ASSY (②).

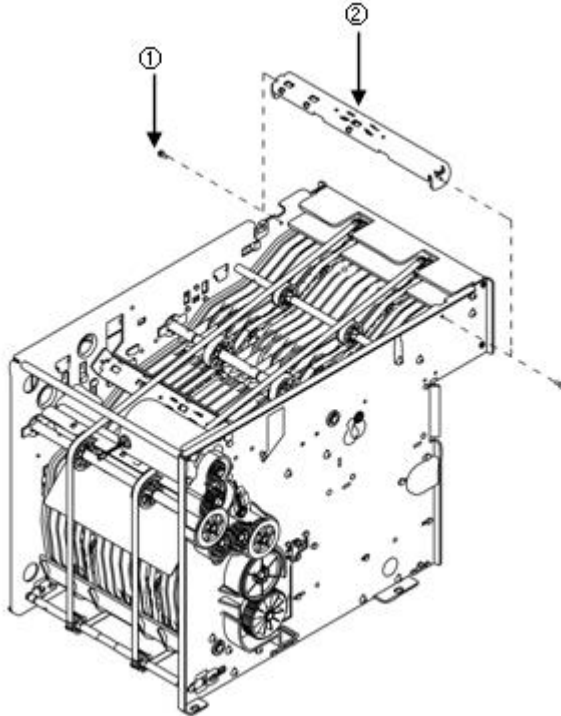

4. Remove 2 screws (①) and disassemble holder (⑤) / sensor (③) /sensor (④).
5. To assemble again, use the reverse order of disassembling.

<Note!> Be sure to check the position of sensor and assemble it. (Refer to figure below)

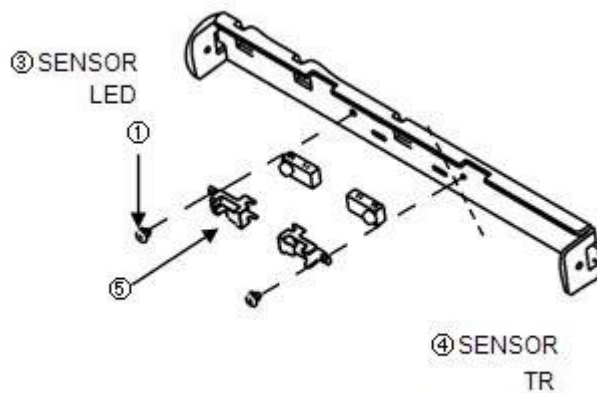

2) CS4

1. Disassemble main cover. (Refer to 1 of “Disassembly of Double Bill Detection Section”)
2. Disassemble cable (CS4). (Section A on figure of “Disassembly of Double Bill Detection Section”)
3. Remove 2 screws (①) and disassemble Sensor Assy (②).

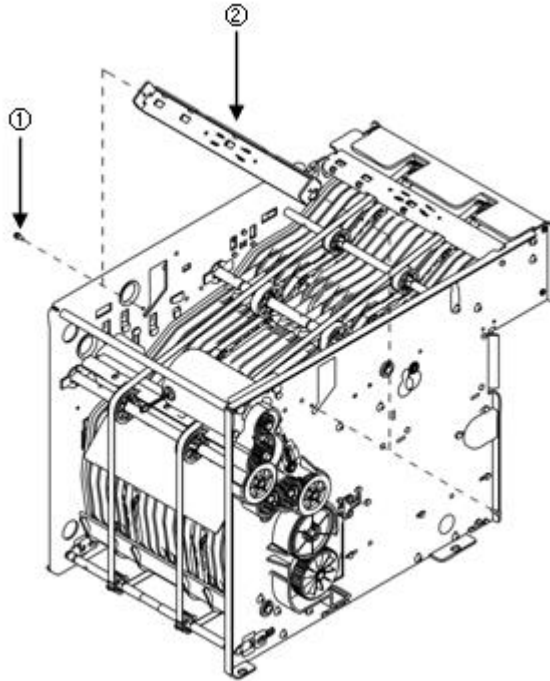

4. Remove 2 screws (①) and disassemble holder (⑤) to disassemble sensor (③) and sensor (④)

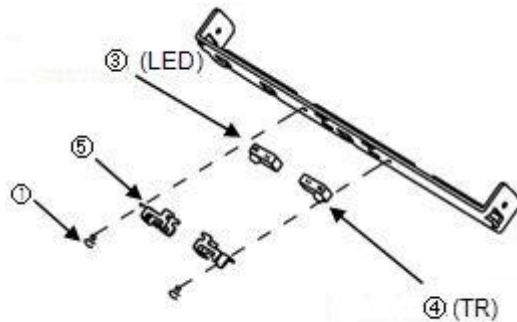

5. To assemble again, use the reverse order of disassembling.
<Note!> Be sure to check the position of sensor and assemble it.

3) CS1_LED

1. Separate cassette and place the unit as shown in figure below.
2. Disassemble sensor (2ea, ①) of ASSY MOLD LOWER DOWN.
3. Disassemble cable connector (CS1_A,CS1_B) of SENSOR.

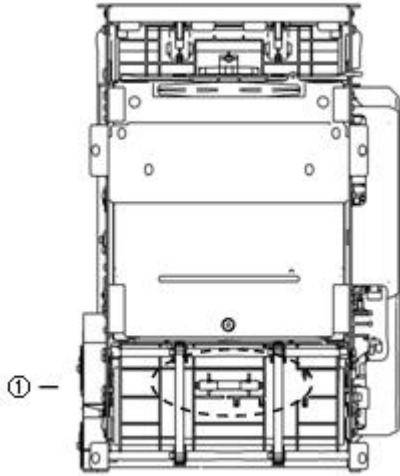

4. To assemble again, use the reverse order of disassembling.
<Note!> Be careful for the direction of cable (CS1_A,CS1_B).

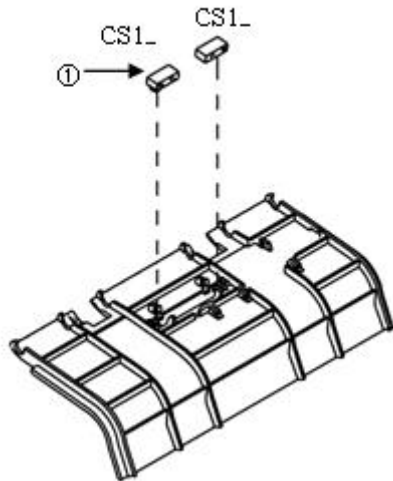

4) CS1_TR

1. Separate the cassette.

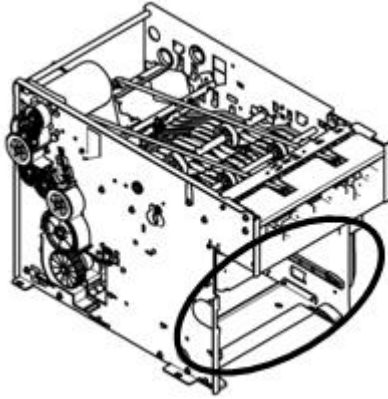

2. If the cassette is separated, the sensor inside ASSY MOLD LOWER FEED UP will be shown.

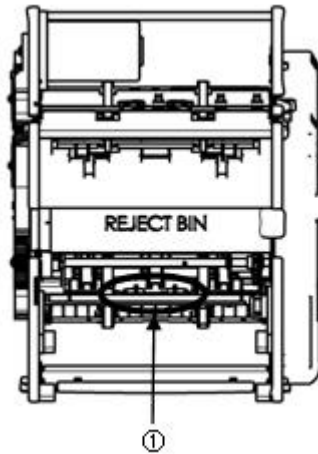

3. Disassemble sensor (2ea, ②) as shown in figure.
 4. Disassemble the cable connector (CS1_A, CS1_B) of sensor .
 5. To assemble again, use the reverse order of disassembling.
- <Note!>** Be careful for the direction of the cable (CS1_A, CS1_B).

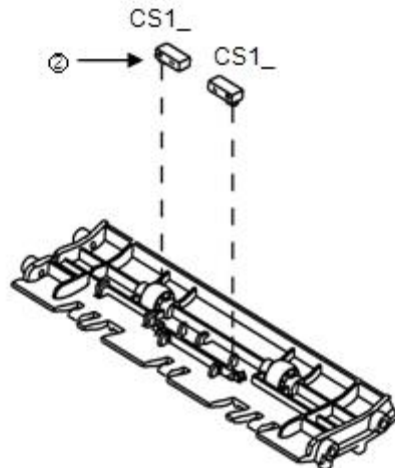

► Disassembly of Separated Type Sensor

1) CS3, CS8

1. Disassemble the main cover. (Refer to 1 of “Disassembly of Double Bill Detection Section”)
2. Disassemble CABLE CS3/CS8.
3. Disassemble sensor (①) on CS3: Section A pressing it in the direction of arrow.
4. Remove a screw (CS8: ③) and disassemble encoder. Then disassemble the sensor (②) on section B pressing it in the direction of arrow.

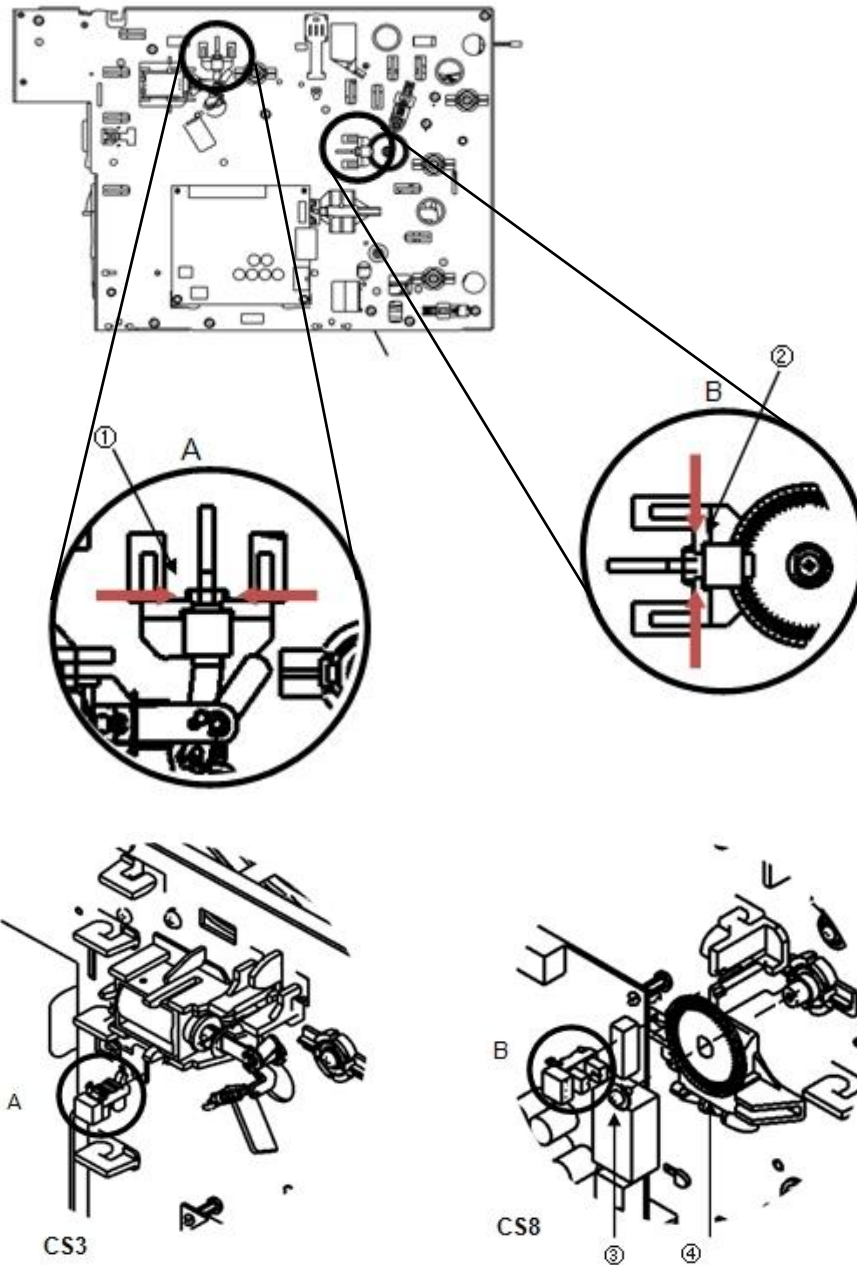

5. To assemble again, use the reverse order of disassembling.

Motor Disassembly

► Motor Disassembly

1. After disassembling cable (M1) on section A, remove 3 screws (①) and disassemble Assy Motor (②)

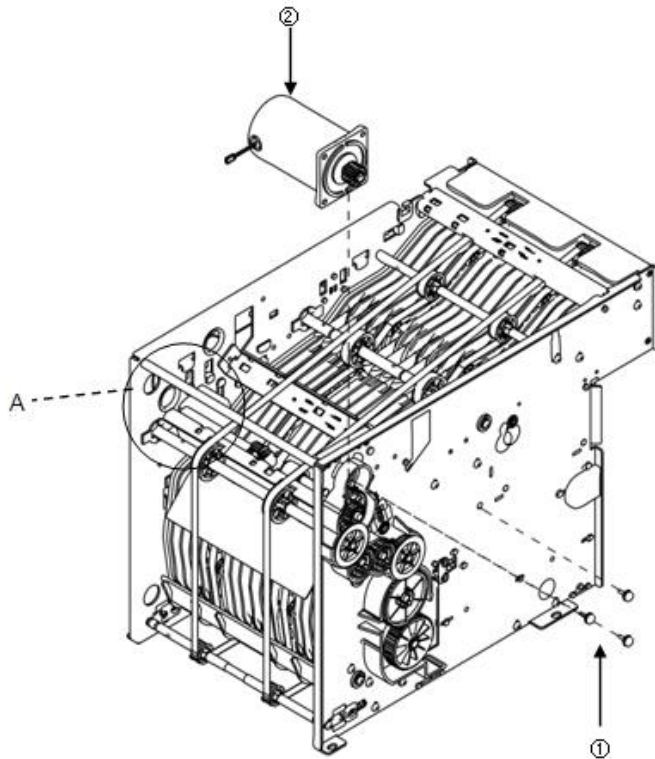

2. Disassemble GEAR (③) and E-RING (④) from Assy Motor.

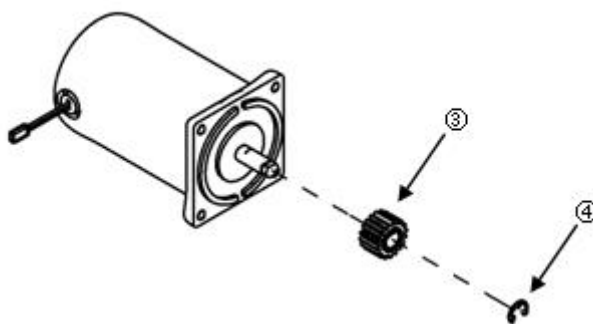

3. To assemble again, use the reverse order of disassembly.

Solenoid Disassembly

► Solenoid Disassembly

1. Remove 2 screws (①) and disassemble the main cover (②)
2. Disassemble the cable (SOL1) on section A.

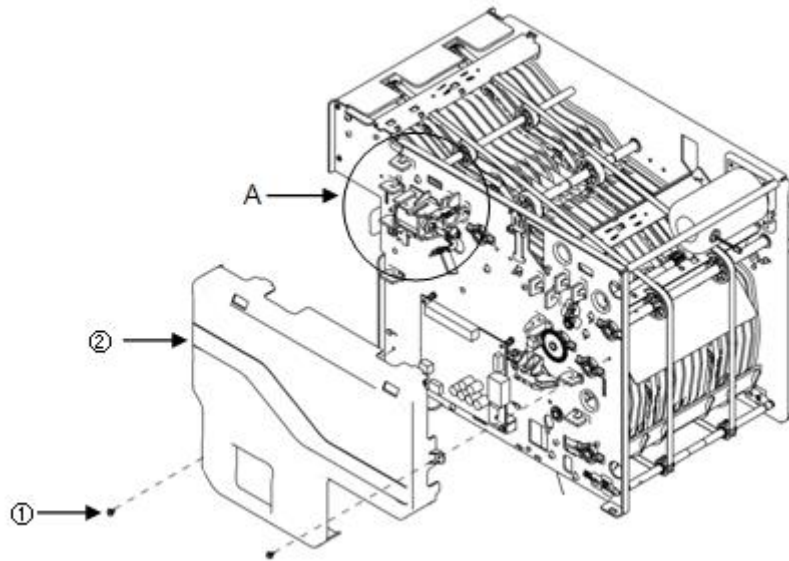

3. Disassemble e-ring (③) connected to solenoid and bracket. Then disassemble Assy Solenoid.

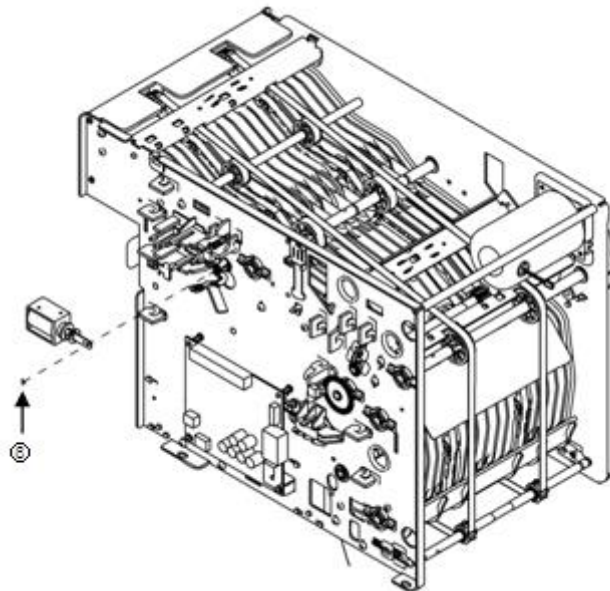

4. Disassemble the solenoid from Solenoid Assy.

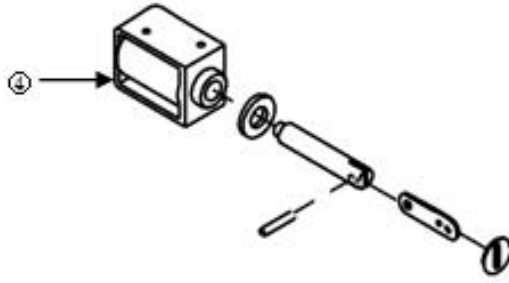

5. To assemble again, use the reverse order of disassembly.
<Note!> Be careful not to miss the rubber damper.

Clutch Disassembly

► Clutch Disassembly

1. Disassemble the main cover. (Refer to 1 of "Disassembly of Double Bill Detection Section")
2. Separate the cassette and disassemble the cable on the inside.
3. Remove a screw (①) and disassemble the gear (②)
4. Disassemble ASSY GEAR (③).

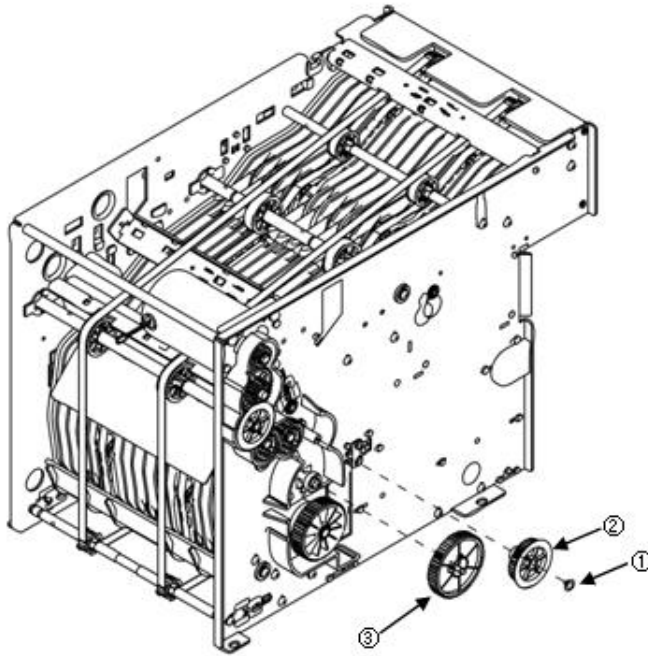

5. Remove a screw (④) and disassemble Assy Clutch in the direction of arrow.

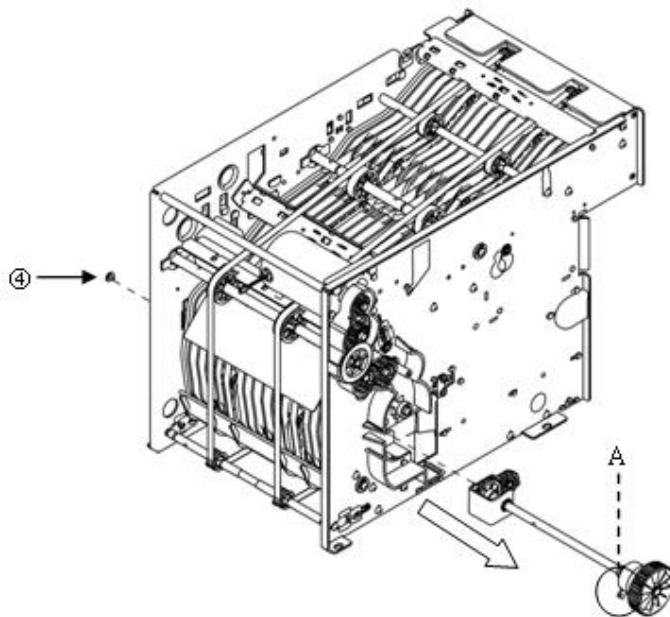

<Note!> Be careful not to damage section A of above figure during disassembling.

6. Unfasten the Set Screw as shown in figure (5) and disassemble the clutch. (Please use the hexagon wrench during disassembling.)

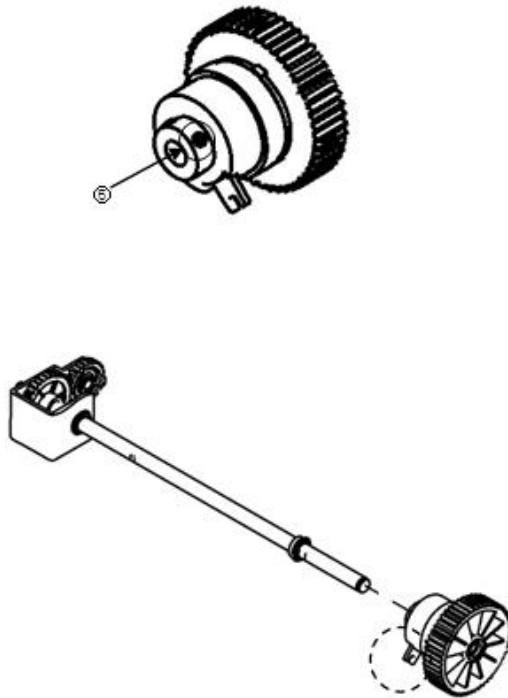

7. To assemble again, use the reverse order of disassembling.

<Note!> Apply the Loctite 242 on the screw thread before assembling Set Screw.

PCBA Disassembly

▶ PCBA Disassembly

1. Disassemble the main cover. (Refer to 1 of "Disassembly of Double Bill Detection Section")
2. Disassemble CABLE ASSY [① SENSOR / ② CLUTCH MOTOR]
3. Remove 2 screws (③) and disassemble PCBA.

<Note!> Be careful not to damage Section A on the upper part when detaching PCBA.

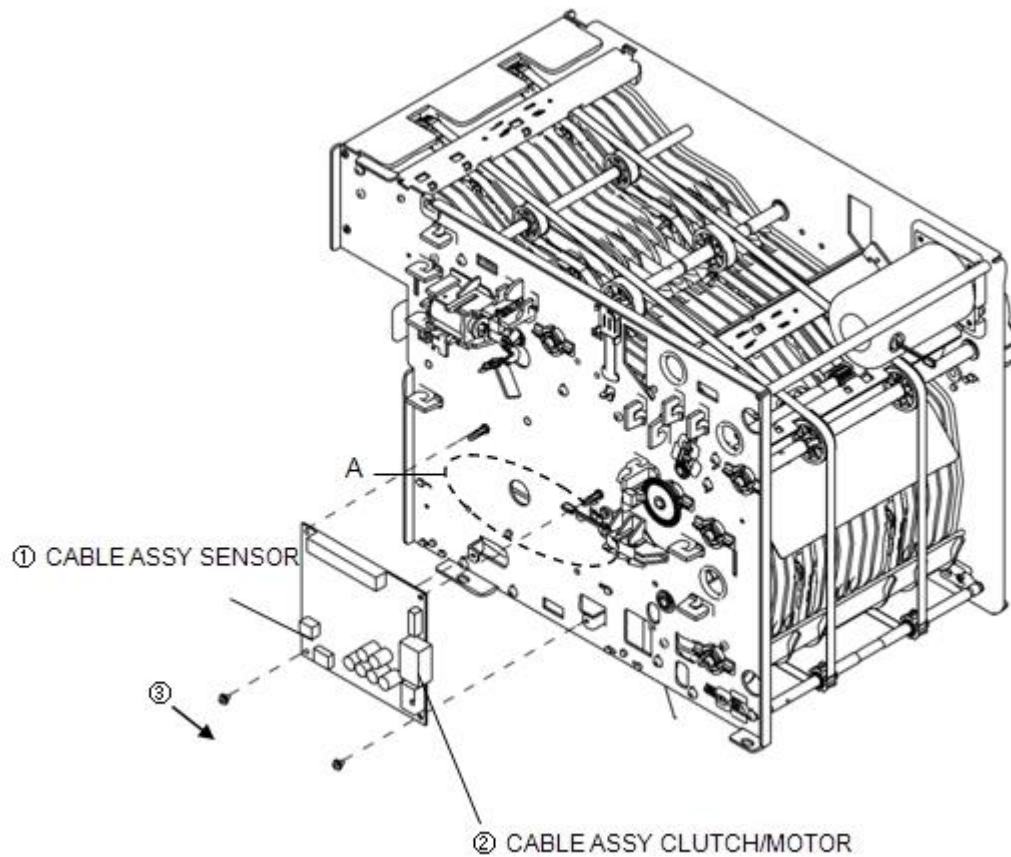

4. To assemble again, use the reverse order of disassembly.

Preventive Maintenance

Lubrication

Lubrication Standard

▶ General Information of Lubrication Standard

1. Lubricate the part instructed in the drawing and follow the lubrication standard for lubrication type of each part and its amount.
2. Description of symbol for lubrication amount

| Symbol | Description | Remark |
|--------|---|--------|
| G | Lubricate slightly with grease using the brush below number 10. (Remove an unnecessary piece of oil.) | |

<Note!> Grease 0.1g is equivalent to about 1.2mm squeezed by grease gun whose inlet is 7mm in diameter.

3. The type of lubricant

| Type | Name | Remark |
|------------|-----------------------|--------|
| Grease(G1) | G-501 (White) | |
| Grease(G2) | ALVANIA EP#1 (Yellow) | |

Lubrication Standard for each part

▶ Lubrication Standard for each part

| Part | Description | Point | Type |
|------|-----------------------|----------|------|
| A | SPRING:GATE_SOLENOID | 1 place | G1 |
| B | SPRING:CO-OD35ID45N15 | 4 places | G1 |
| C | | | |
| D | K-ASSY:FRAME_L | 1 place | G2 |
| | K-ASSY:FRAME_R | 1 place | G2 |

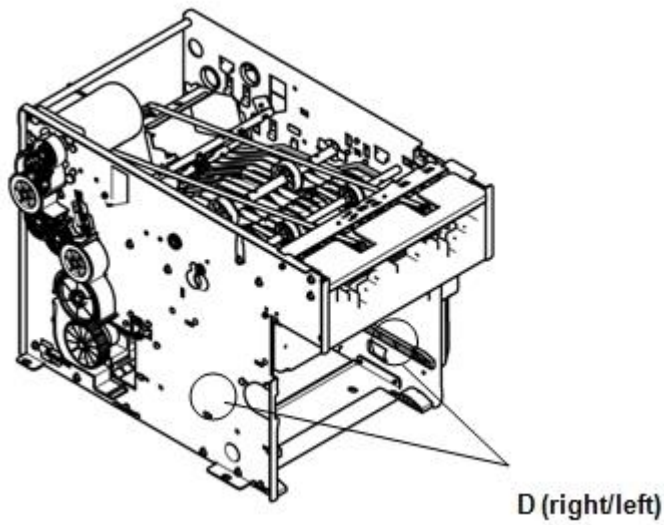
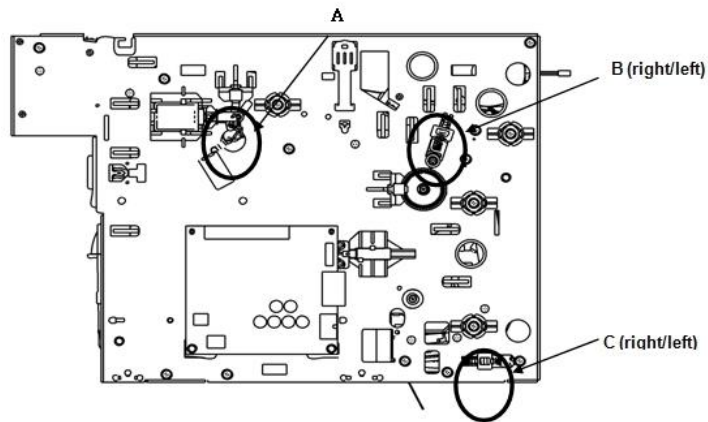

Cleaning (Inspection)

Overview of Cleaning Standard

- ▶ This standard expresses the item for regular cleaning (Inspection)

Cleaning Cycle

- ▶ Cycle of regular cleaning (Inspection)

| Symbol | Description |
|--------|---------------------------------------|
| M6 | Inspection once a six months |
| Y1 | Inspection once a year (Including M6) |

Cleaning Point and Method

- ▶ Sensor (Prism)

1. Remove the foreign substance from the integral transmissive sensor (CS3, CS8) with a small brush for cleaning sensor. (4~6 times a round-trip of brush)
2. Remove the foreign substance from the prism surface of separated transmissive sensor (CS1,CS13,CS4) with a cotton swab.

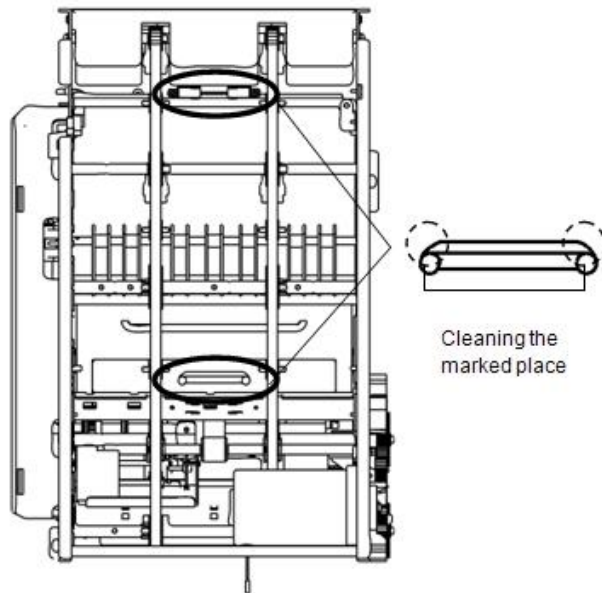

| No | Cleaning Point | Cleaning Cycle | Cleaning Method | Remark |
|----|----------------|----------------|-----------------|--------|
| 1 | Prism | M6 | Cotton Swab | |

► Transport Path

Remove the foreign substances form the transport path with an air brush.

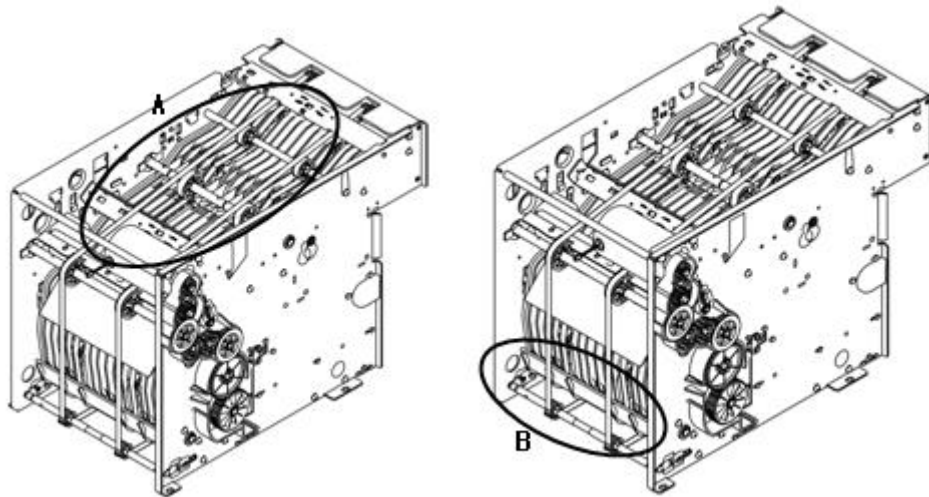

| No | Cleaning Point | Cleaning Cycle | Cleaning Method | Remark |
|----|----------------|----------------|-----------------|--------|
| 1 | MAIN FEED (A) | M6 | AIR BRUSH | |
| 2 | LOWER FEED (B) | M6 | AIR BRUSH | |

► Double Bill Detection Lever

1. Remove the foreign substances from the double bill detection lever with a air brush.

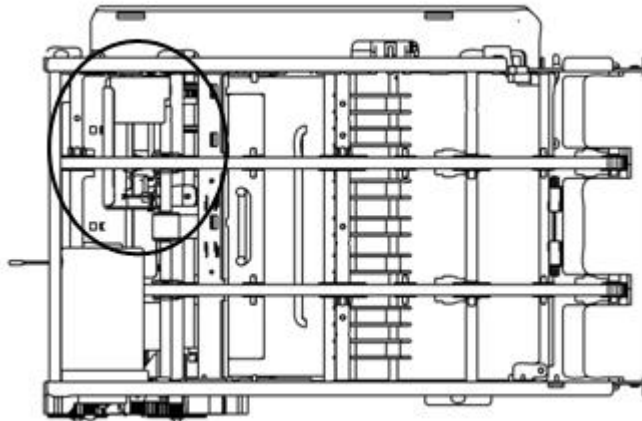







| No | Cleaning Point | Cleaning Cycle | Cleaning Method | Remark |
|----|---|----------------|-----------------|--------|
| 1 | Double Bill Detection Section of the Transport Path | M6 | AIR BRUSH | |

Parts Replacement

Required Tools for Replacement

► Required Tools

| NO | Name of Tool | Picture |
|----|-------------------------|--|
| 1 | + Driver |  |
| 2 | - Driver |  |
| 3 | Number 1.5 + Driver |  |
| 4 | E-LING CLIP |  |
| 5 | LONG NOSE |  |
| 6 | Spring Hook or Pincette |  |
| 7 | Hexagon Wrench |  |

How to Replace

- ▶ Mounting Catch [Section A] in case of RJ Catch Damage
 1. Mount the cassette catch. After removing damaged RJ Catch Section (①), mount a Catch (②).

<Note!> Assemble 2 screws (M2.5X8).

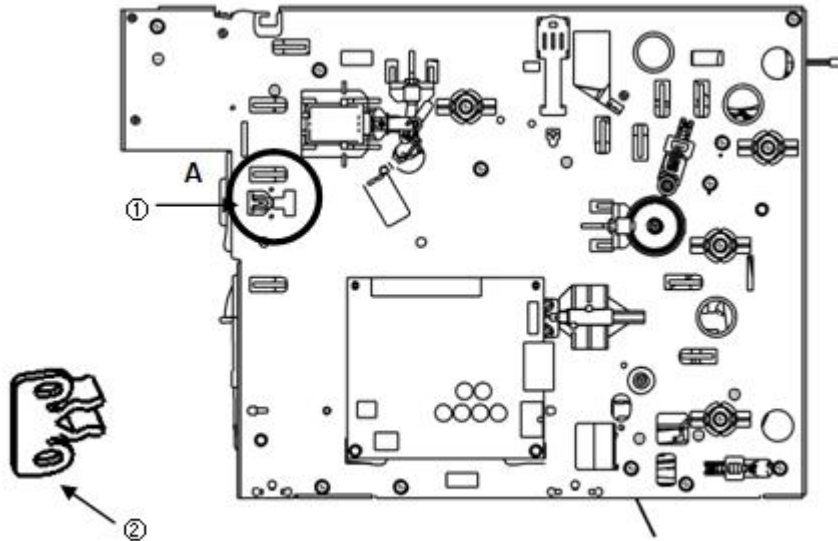

- ▶ Mounting Catch [Section B] in case of Cassette Catch Damage
 1. Unfasten a screw (M2.5X8) in case of damage and remove the damaged Catch. Then replace it with new one.

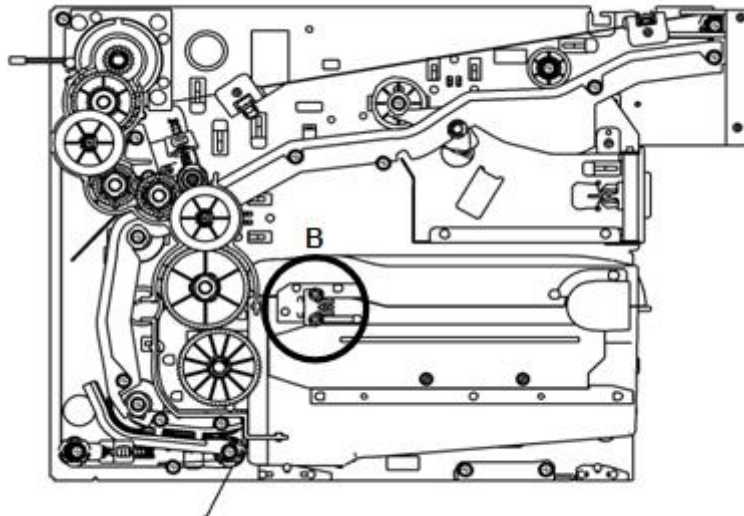

Troubleshooting

- ▶ How to remove a jam
Take out the jammed note pulling the belt as shown in below picture.

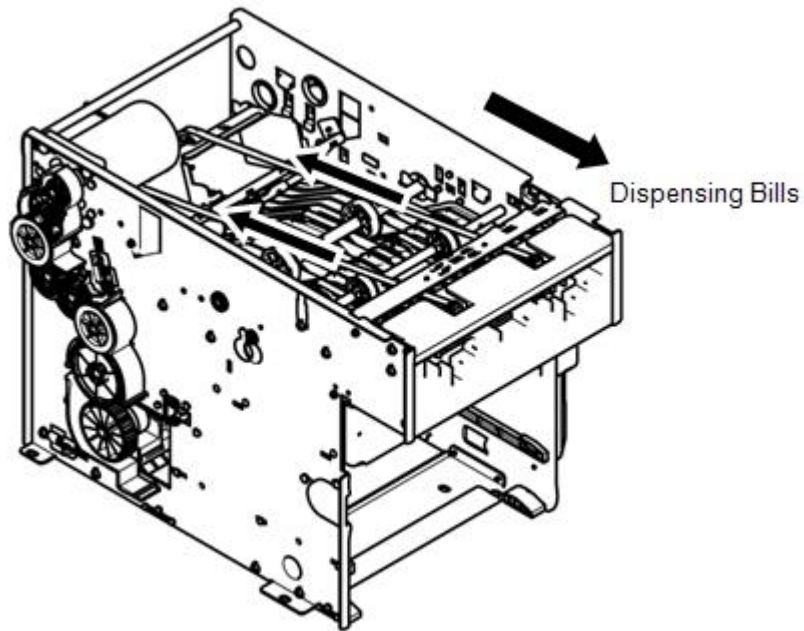

CDU-M

Appearance/Functional Diagram

- ▶ The following figures show the three sectional diagrams of the CDU. CDU is 623.00mm (24.53inch) high and 303.00 mm (11.93inch) wide.

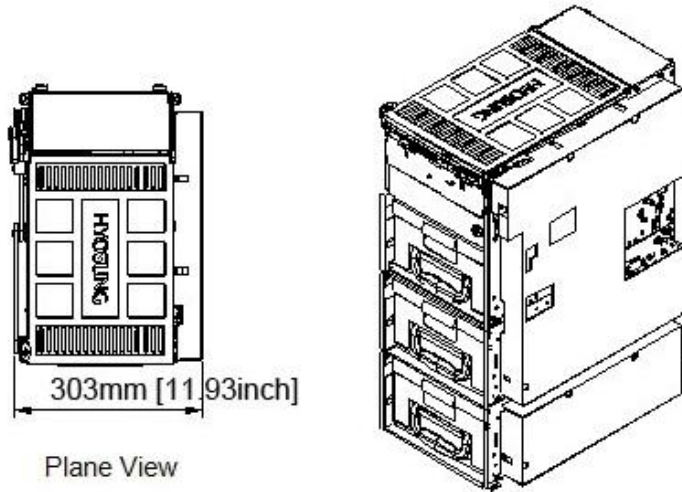

Plane View

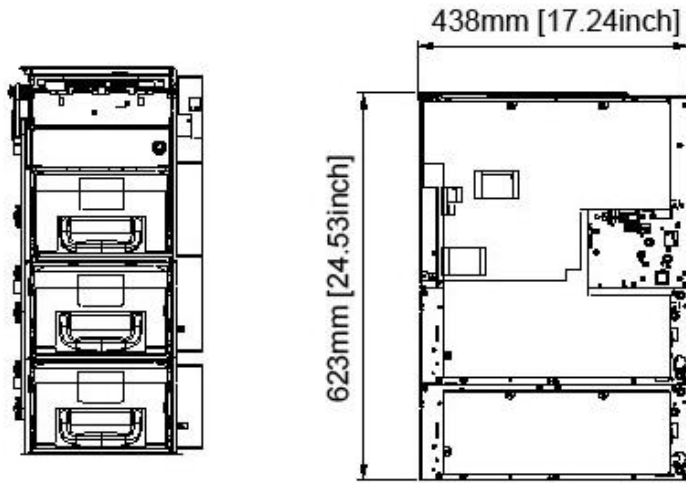

Front View

Side View (Right)

Cassette

- ▶ The following figures show three sectional diagrams of the cassette. Cassette is 137.50mm (5.41inch) high, 217.00mm (8.54inch) wide and 342mm (13.46inch) long.

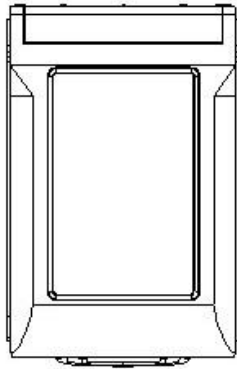

Plane View

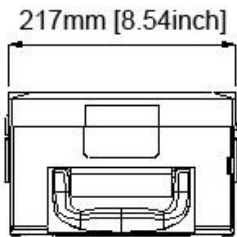
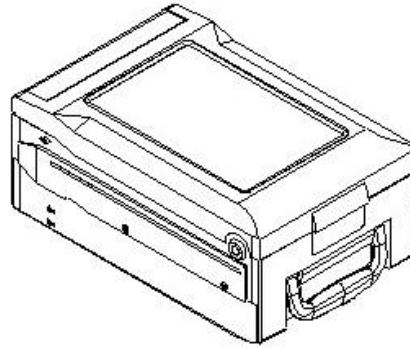

Front View

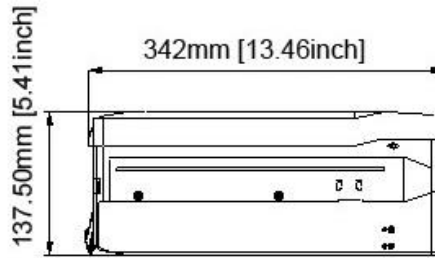

Side View (Right)

Actuator Diagram

► Six actuators are used. The following figure shows their location.

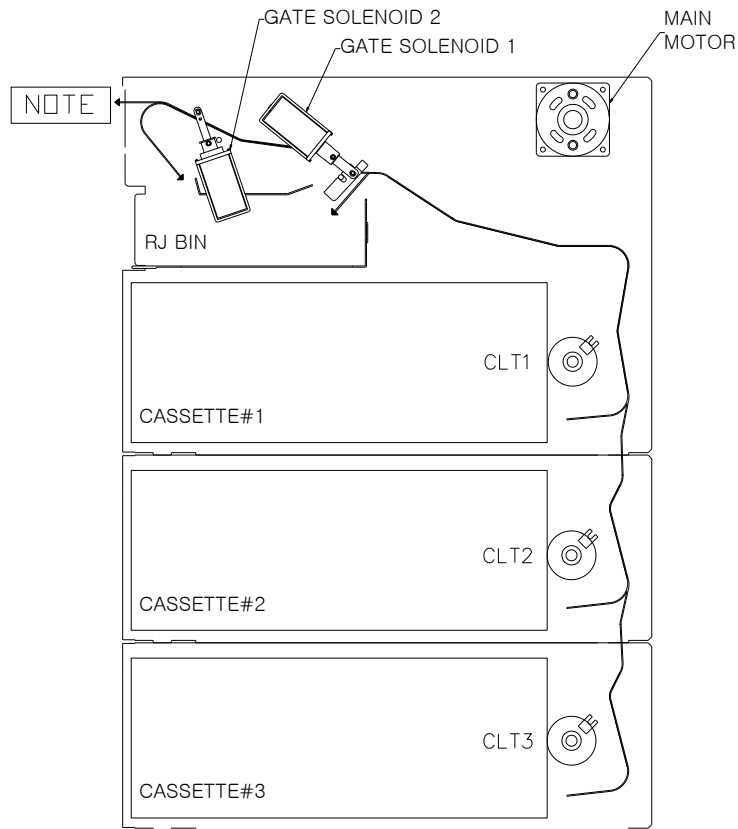

Sensor Diagram

► The following figure shows the location of 29 sensors in this system.

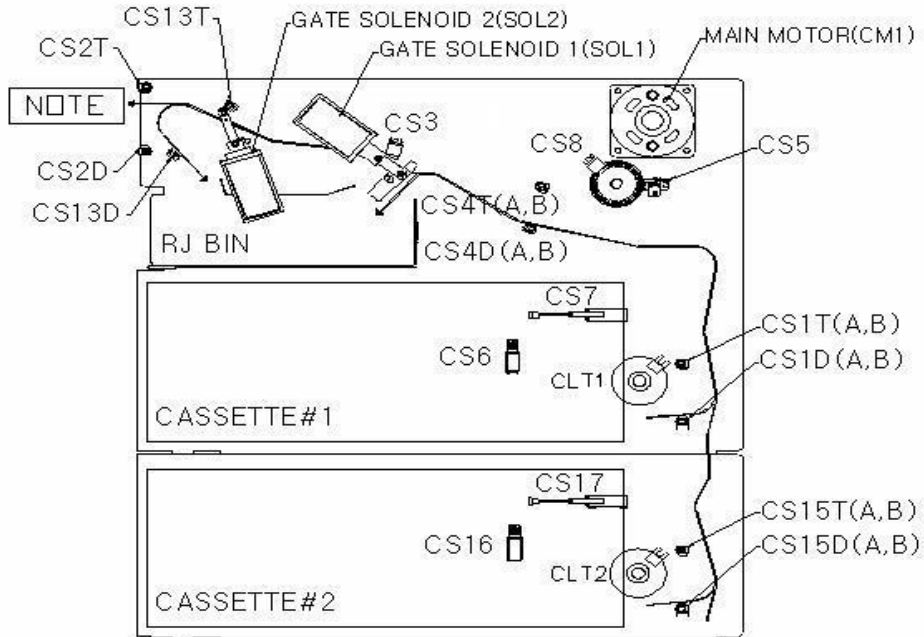

**<Note!> A = Sensor far from the board.
B = Sensor close to the board.**

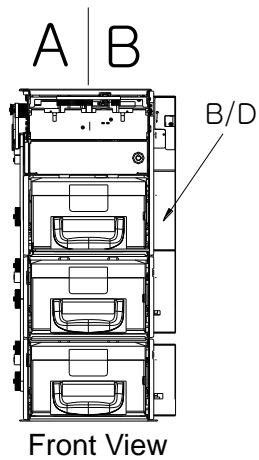

Module and Sensor Replacement

Sensor Replacement

- ▶ Turn the power off and remove the CDU cover as shown in the figure to replace sensors and modules. The CDU contains a total of 28 sensors including 20 returning path sensors, 1 gate operation detection sensor, 3 cassette position detection sensors, 3 remaining note detection sensors and 1 encoder sensor.

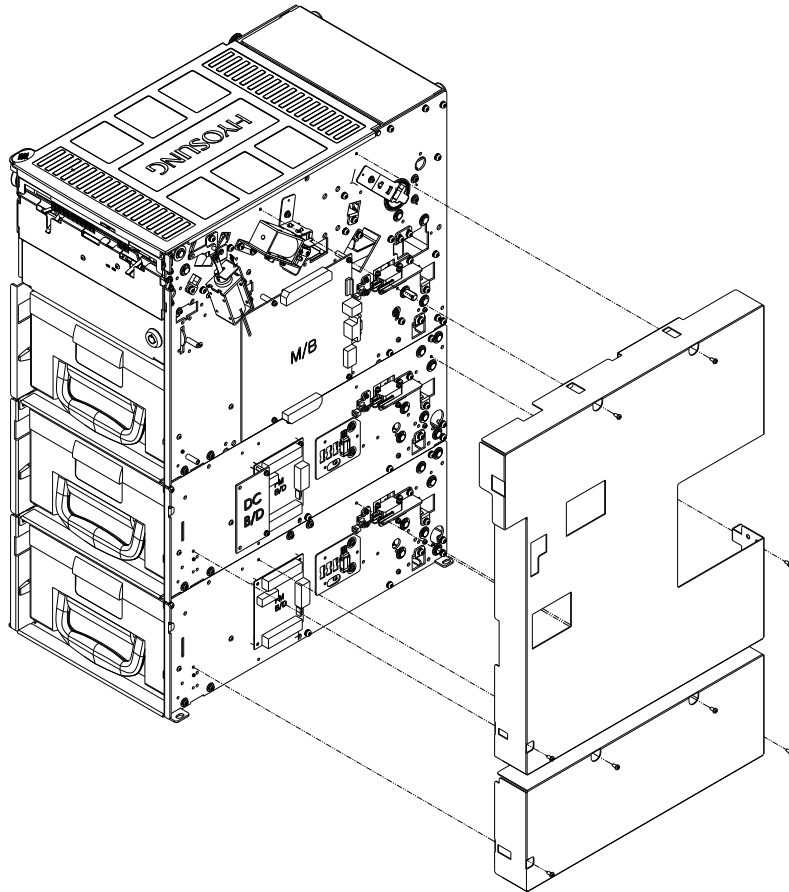

► Returning Path Sensor

1) CS1D(A,B), CS15D(A,B), CS31D(A,B)

1. Remove the sensor bracket M4 screws (2 places each) as shown in the figure below.
2. Remove the connector and the cable tie to remove the sensor bracket. Be careful not to break the connector pin when removing.
3. Remove the sensor bracket.
4. From the removed sensor bracket, remove the M3 sensor screws (1 place each) of the sensor which will be replaced.
5. Replace the sensor.
6. Assemble the unit in the reverse order - 4~1.

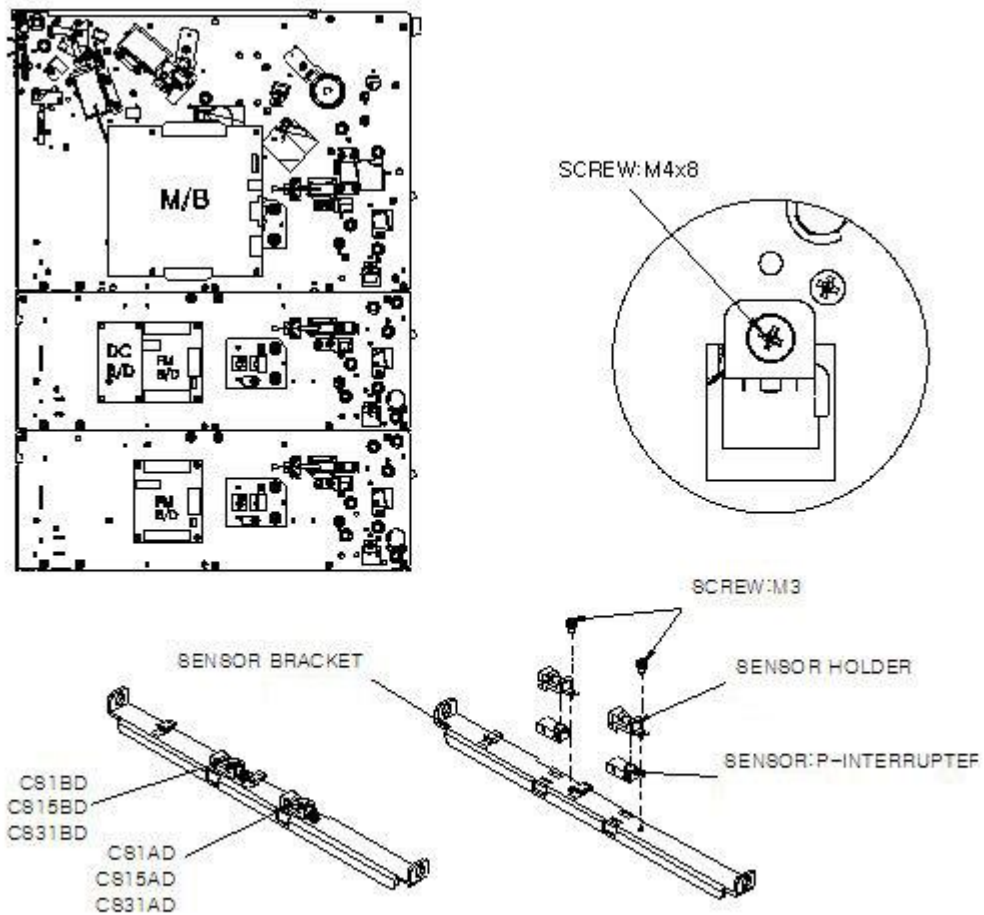

2) CS1T(A,B), CS15T(A,B), CS31T(A,B)

1. Remove the sensor bracket M4 screws (2 places each) from the sensor bracket.
2. Remove the connector and the cable tie to remove the sensor bracket. Be careful not to break the connector pin when removing.
3. Remove the sensor bracket.
4. From the removed sensor bracket, remove the M3 sensor screws (1 place each) of the sensor which will be replaced.
5. Replace the sensor.
6. Assemble the unit in the reverse order - 4~2.

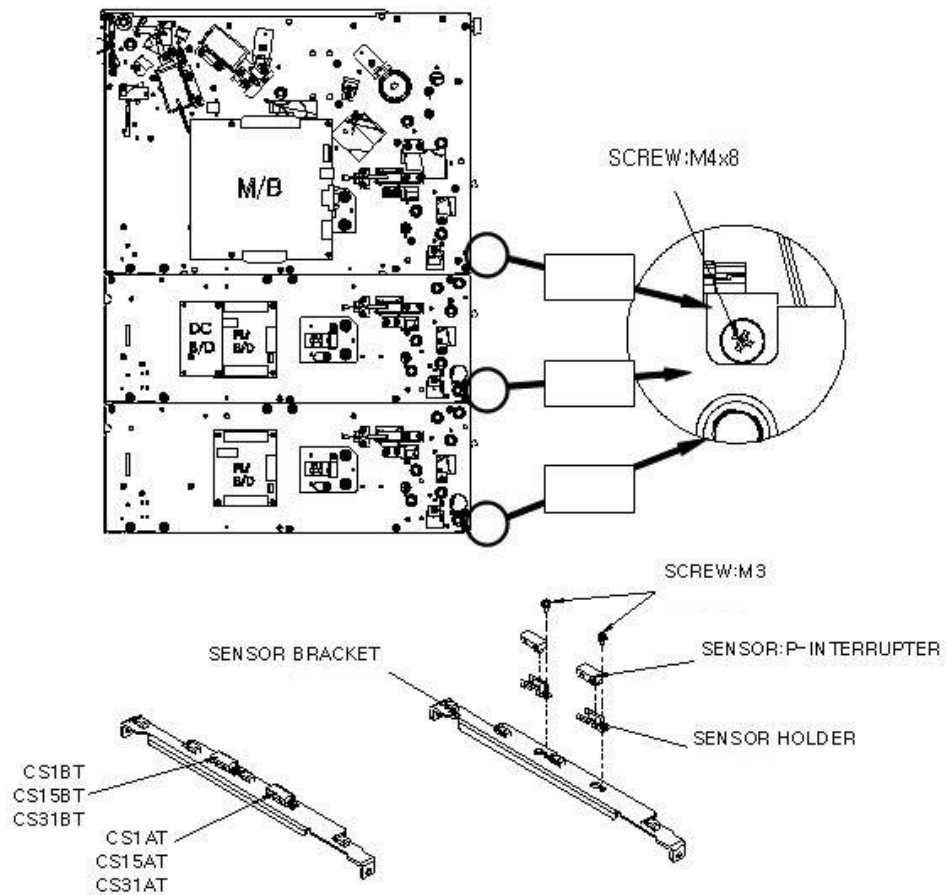

3) CS2D

1. Remove the M3 screws (4 places) of the sensor bracket.
2. Remove the connector and the cable tie to remove the sensor supporter. Be careful not to break the connector pin when removing.
3. Remove the M3 sensor screw (1 place).
4. Remove the M3 sensor fastening screws from the removed sensor bracket.
5. Replace the sensor.
6. Assemble the unit in the reverse order - ④~①. Make sure to fasten the spacer and the screw end is not protruding out to the other side of the bracket.

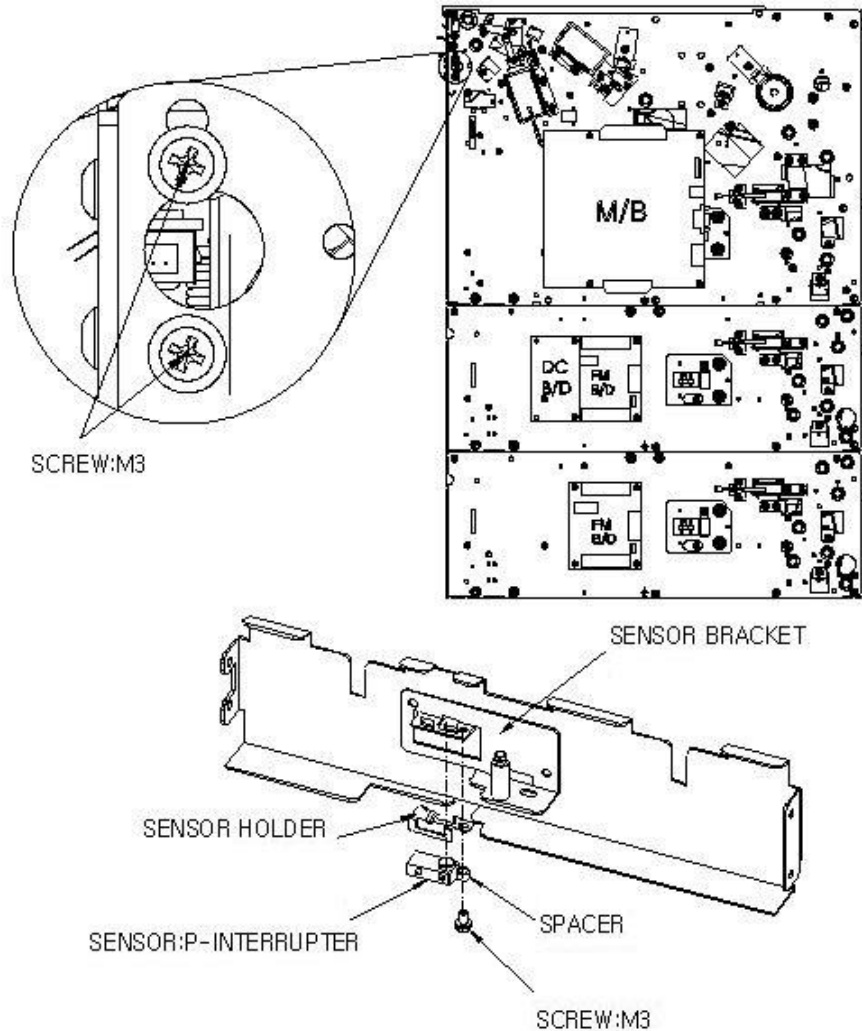

4) CS2T

1. Remove the M3 screws (4 places) of the sensor bracket.
2. Remove the connector and the cable tie to remove the sensor supporter. Be careful not to break the connector pin when removing.
3. Remove the sensor bracket.
4. Remove the M3 sensor fastening screws from the removed sensor bracket.
5. Replace the sensor.
6. Assemble the unit in the reverse order - 4~1.

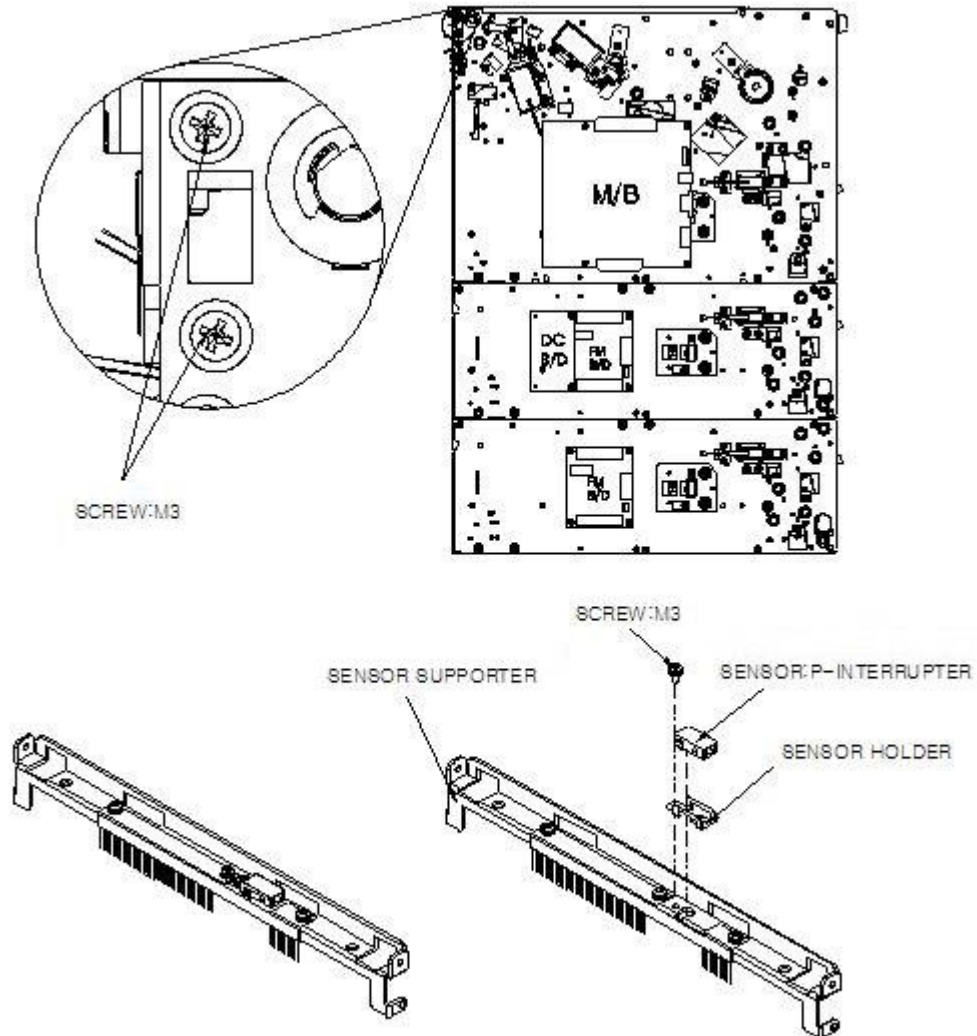

5) CS4D (A, B)

1. Remove the M3 screws (2 places) of the sensor bracket.
2. Remove the connector and the cable tie to remove the sensor supporter. Be careful not to break the connector pin when removing.
3. Remove the sensor bracket.
4. Remove the M3 sensor fastening screws to replace from the removed sensor bracket.
5. Replace the sensor.
6. Assemble the unit in the reverse order - 4~1. Make sure to fasten the spacer and the screw end is not protruding out to the other side of the bracket.

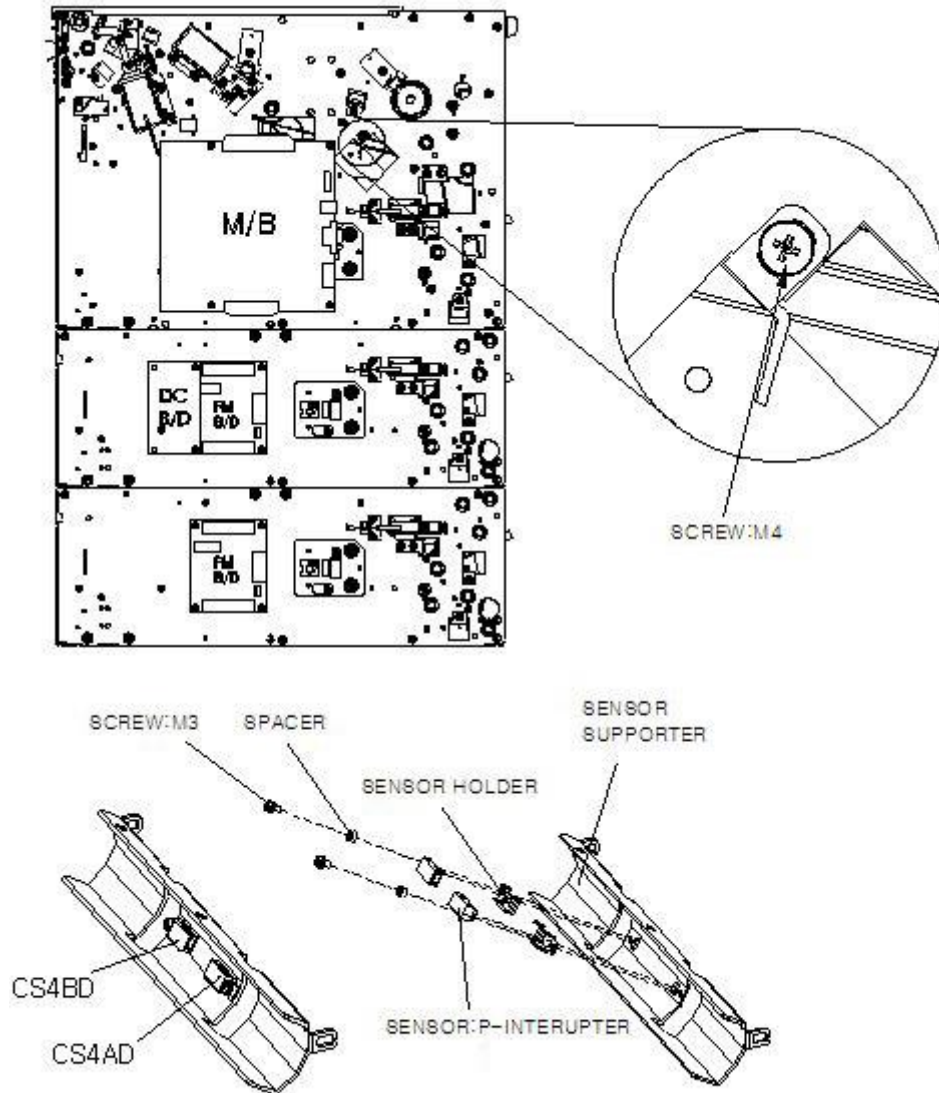

6) CS4T (A, B)

1. Remove the M3 screws (2 places) of the sensor bracket at the left and right sides.
2. Remove the connector and the cable tie to remove the sensor supporter. Be careful not to break the connector pin when removing.
3. Remove the sensor bracket.
4. Remove the M3 sensor fastening screws of the sensor to replace from the removed sensor bracket.
5. Replace the sensor.
6. Assemble the unit in the reverse order - 4~1.

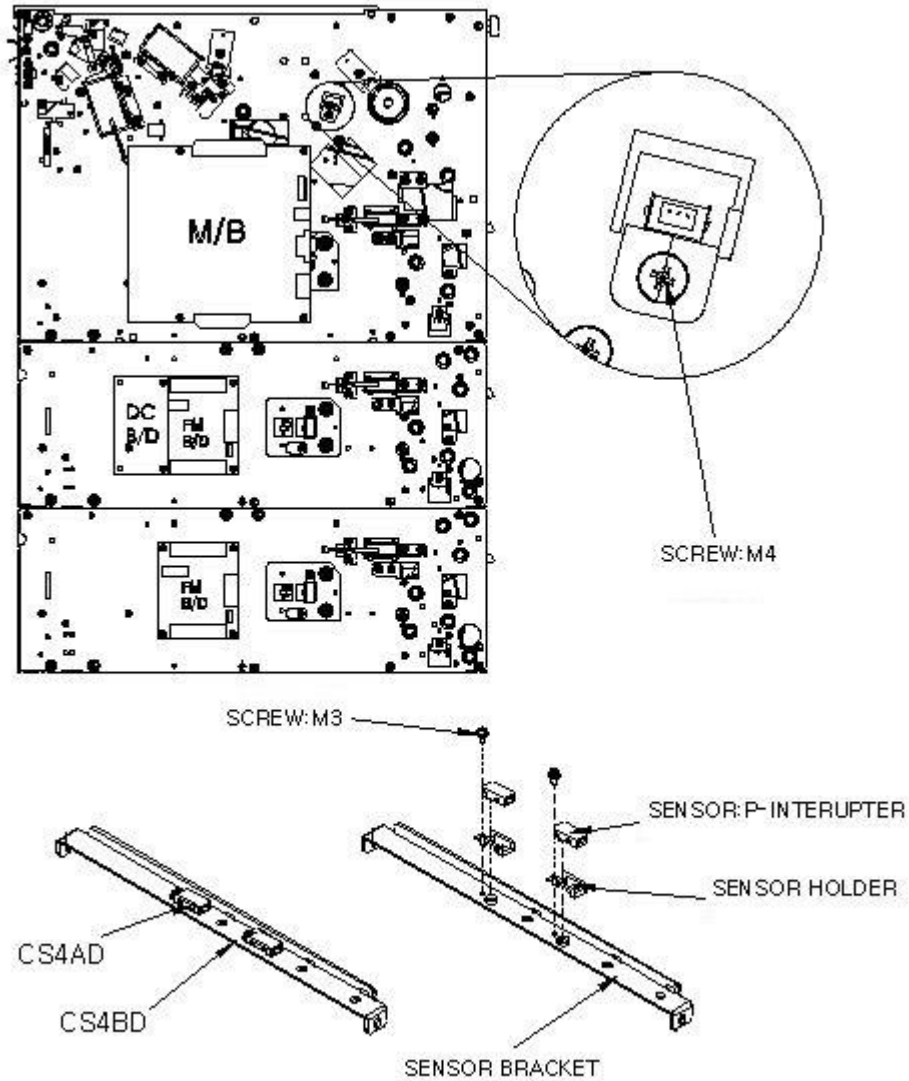

7) CS13D

1. Remove the M3 screws (4 places) of the sensor bracket.
2. Remove the connector and the cable tie to remove the sensor supporter. Be careful not to break the connector pin when removing.
3. Remove the sensor bracket.
4. Remove the M3 sensor fastening screws to replace from the removed sensor bracket.
5. Replace the sensor.
6. Assemble the unit in the reverse order - 4~1. Make sure to fasten the spacer and the screw end is not protruding out to the other side of the bracket.

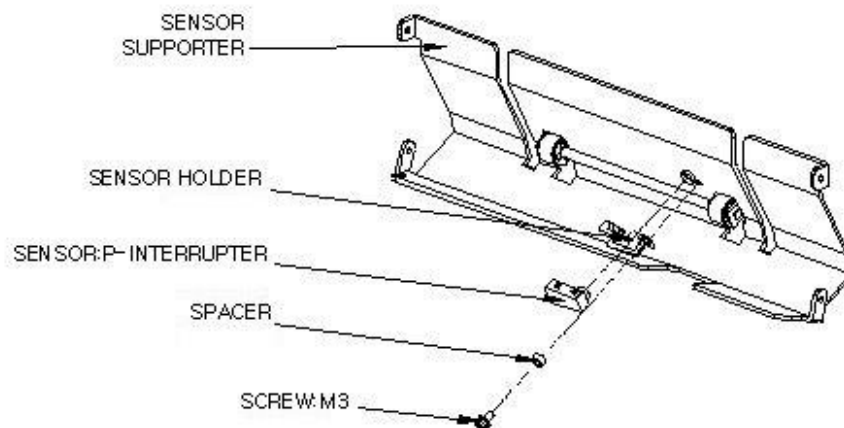
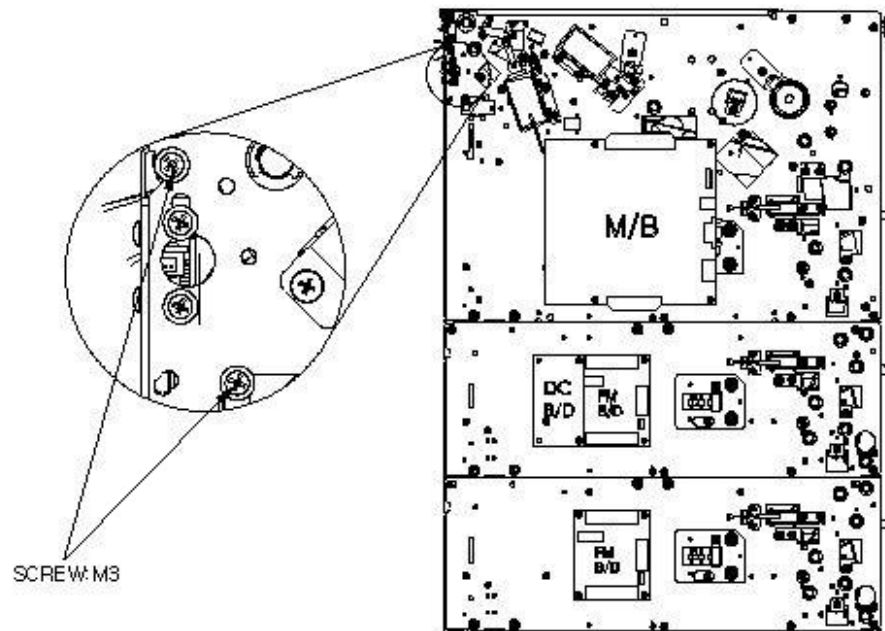

8) CS13T

1. Remove the M3 screws (1 place) of the sensor bracket.
2. Remove the connector and the cable tie to remove the sensor supporter. Be careful not to break the connector pin when removing.
3. Remove the sensor bracket.
4. Remove the M3 sensor fastening screws from the removed sensor bracket.
5. Replace the sensor.
6. Assemble the unit in the reverse order - 4~1. Make sure to fasten the spacer and the screw end is not protruding out to the other side of the bracket.

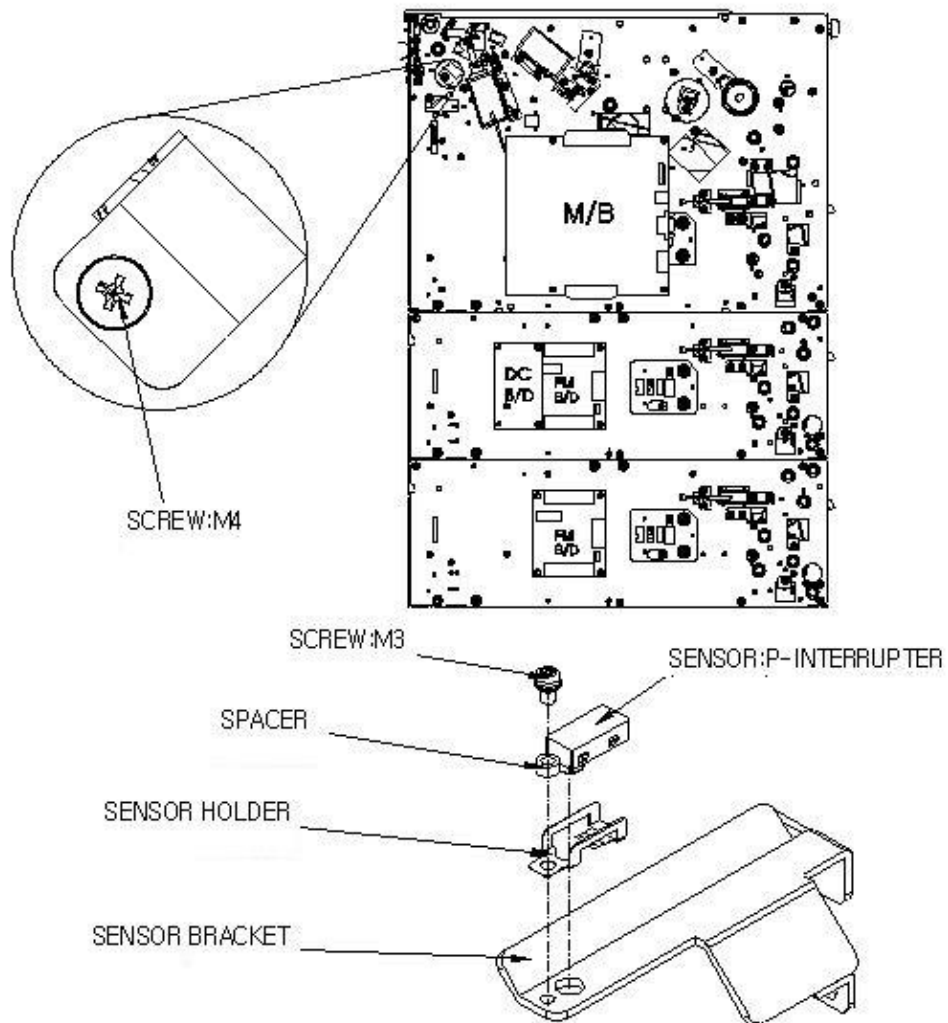

2) Gate Operation Detection Sensor & Encoder Sensor

(1) CS3

1. Remove the M3 screw of the CS3 sensor bracket (1 place).
2. Remove the connector and the cable tie to remove the sensor bracket. Be careful not to break the connector pin when removing.
3. Press the part ② of the sensor gently as shown in the figure below to remove the lock and the sensor.
4. To insert the sensor, insert the part ① first, then press part ② to lock.
5. Assemble in the reverse order - 3~1.

<Note!> When reassembling the CS3, pull the solenoid and adjust the detection bracket to the center of the sensor while the screw is still loose. Then, tighten the screw.

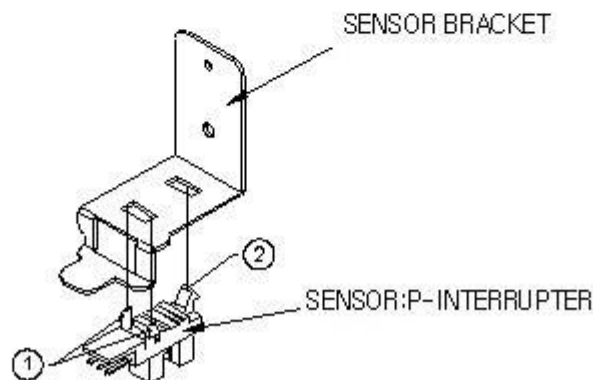
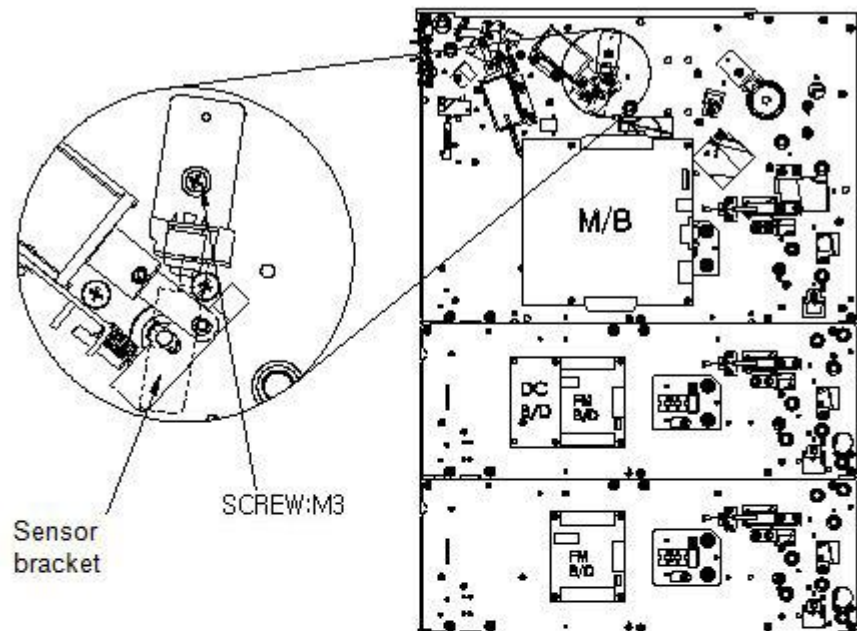

(2) CS8 (Encoder sensor)

1. Remove the M3 screw of the CS8 sensor bracket (1 place).
2. Remove the connector and the cable toe to remove the sensor bracket. Be careful not to break the connector pin when removing.
3. Press part ② of the sensor gently as shown in the figure below to remove the lock and the sensor.
4. To insert the sensor, insert the part ① first, then press part ② to lock.
5. Assemble in the reverse order - 3~1.

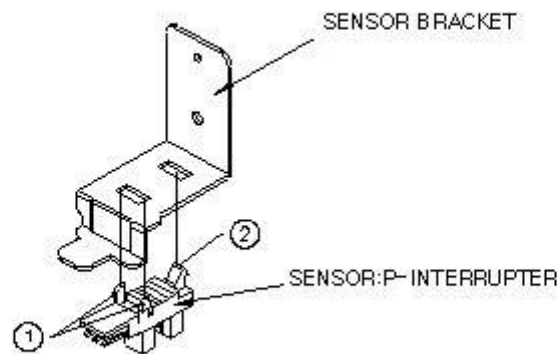
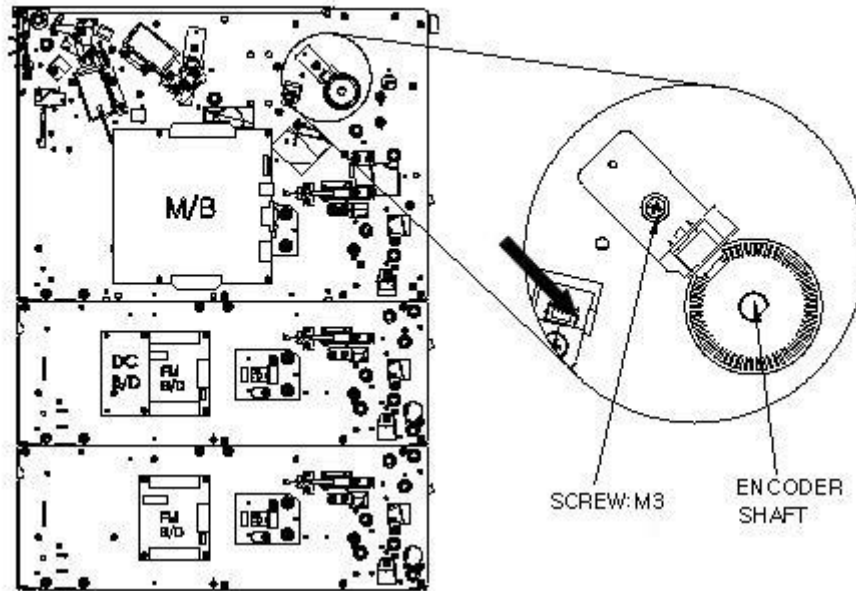

<Note!> Make sure that the sensor always faces towards the center of the encoder shaft as shown in the following figure.

3) Regular Position Sensor

(1) CS7, CS17, CS27

1. Remove the sensor bracket M4 screws (2 places each).
2. Remove the connector and the cable tie to remove the sensor bracket. Be careful not to break the connector pin when removing.
3. Remove the sensor bracket.
4. Remove the MP3 sensor screws (2 places each) from the removed sensor bracket.
5. Replace the sensor.
6. Assemble the unit in the reverse order - 4~1.

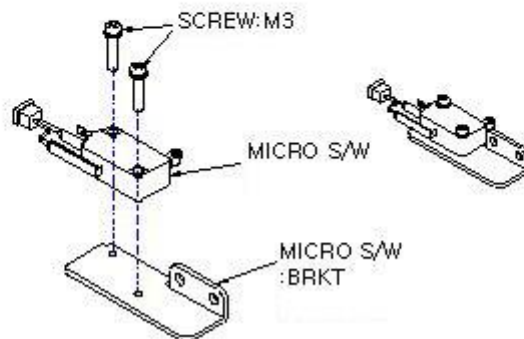
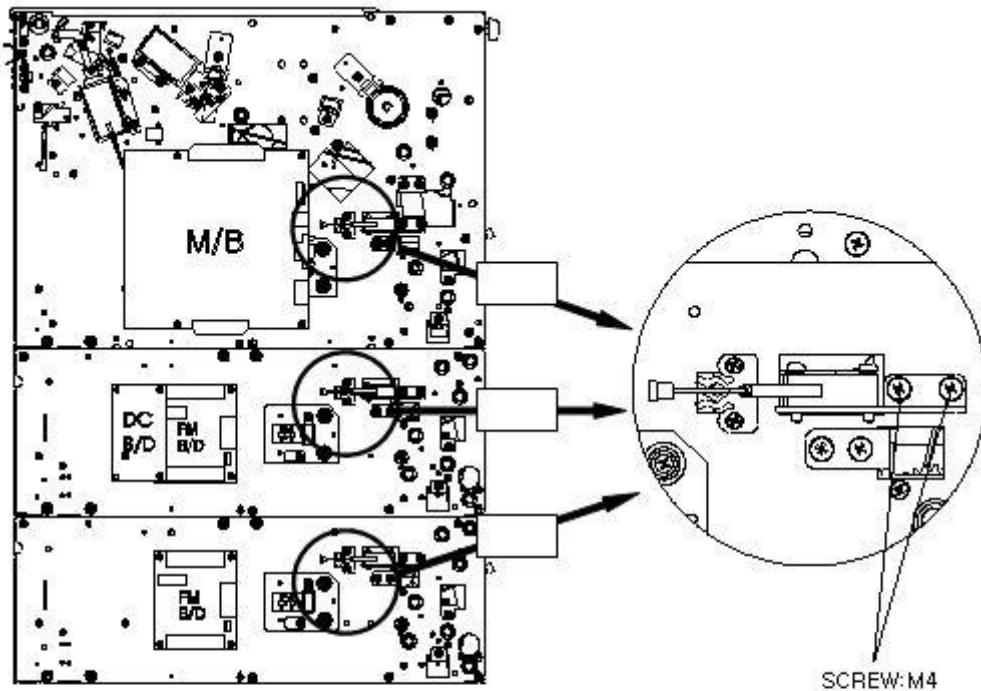

<Note!> Adjust the cassette position when mounting it until a click sound is heard.

4) Remaining Note Sensor

(1) CS6, CS16, CS26

1. Remove the CS6 sensor from the main B/D to replace it. (See the main B/D replacement section)
2. Remove the sensor bracket M3 screws (2 places each).
3. Press the snap lock in the rear of the sensor bracket with your hand and, then remove the sensor
4. Remove the connector. Be careful not to break the connector pin when removing.
5. Replace the sensor.
6. Connect the connector.
7. To assemble the sensor in the bracket, lock it from the front side and press the rear side to fix it.

<Note!> Adjust the sensor by running the variable resistance so that it generates a current below 1.0V if there is cash available and above 3.0V if no cash is available.

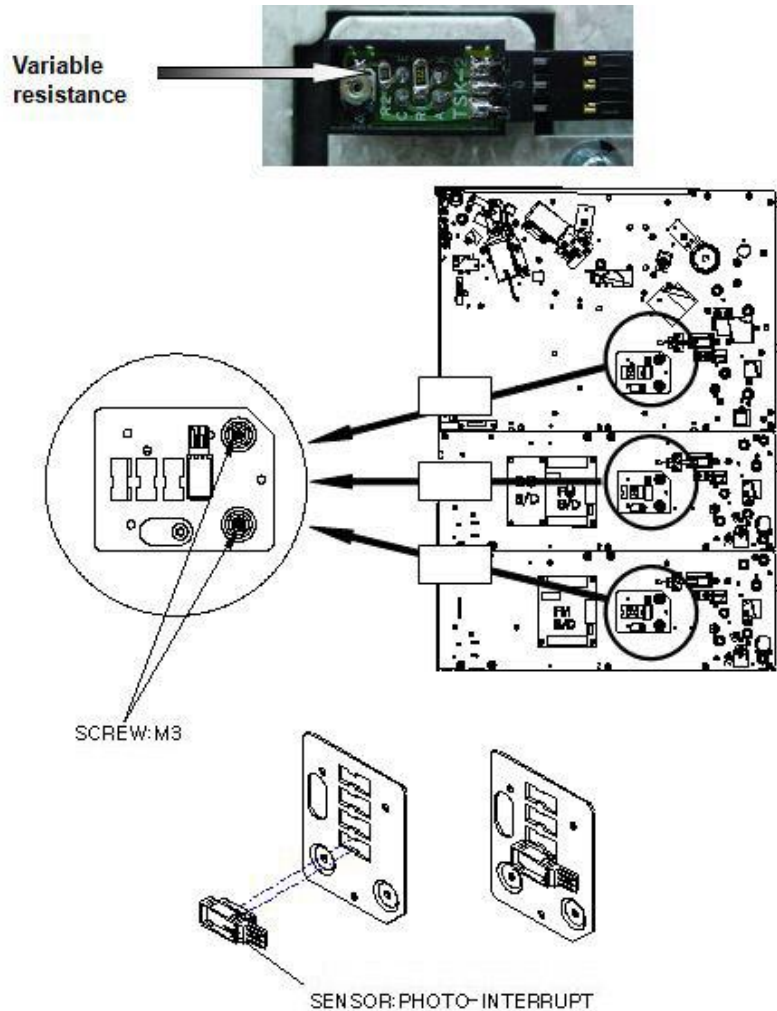

Module Replacement

► B/D assembly

1. The board assembly is composed of the main board and the DC converter board as shown in the following figure.
2. Remove the connector from the board. Be careful not to break the connector pin.
3. Remove the board M3 screws (4 places in the main board, 8 places in the FM board (6 screws, 2 jack posts) and 2 places in the DC board).
4. Replace the board.
5. Assemble in the reverse order – 4 ~ 1.

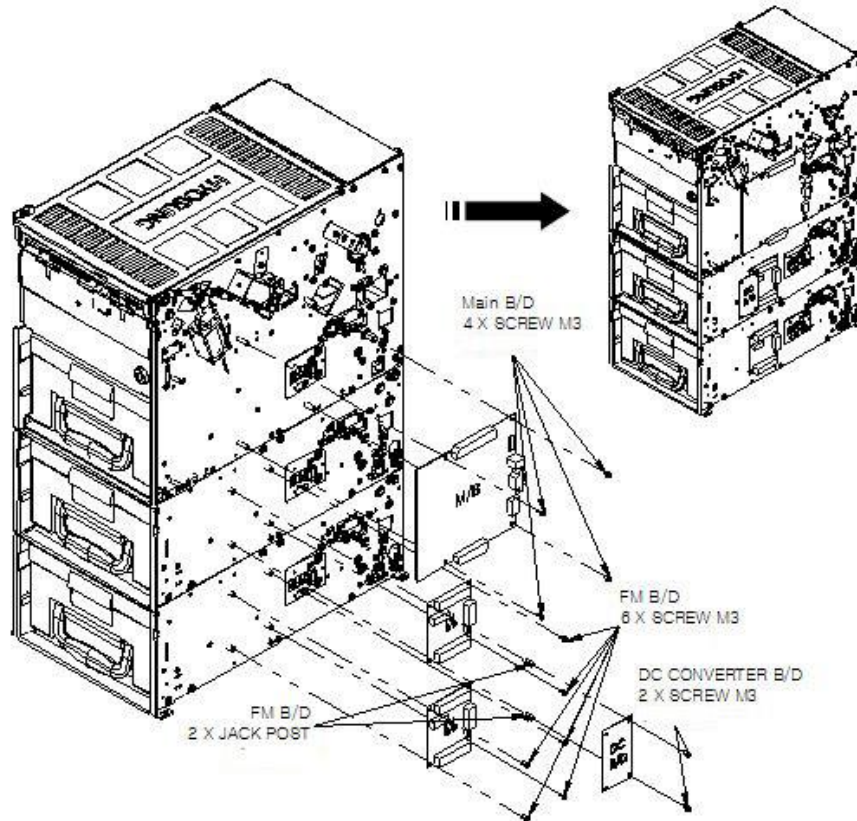

► Main Motor Assembly

1. Remove the main motor cover as shown in the following figure.
2. Remove the power cable from the main motor.
3. Unscrew the main motor fixing screws (M5, 4 places).
4. Remove the main motor assembly and replace it.
5. Assemble in the reverse order – 4 ~ 1.

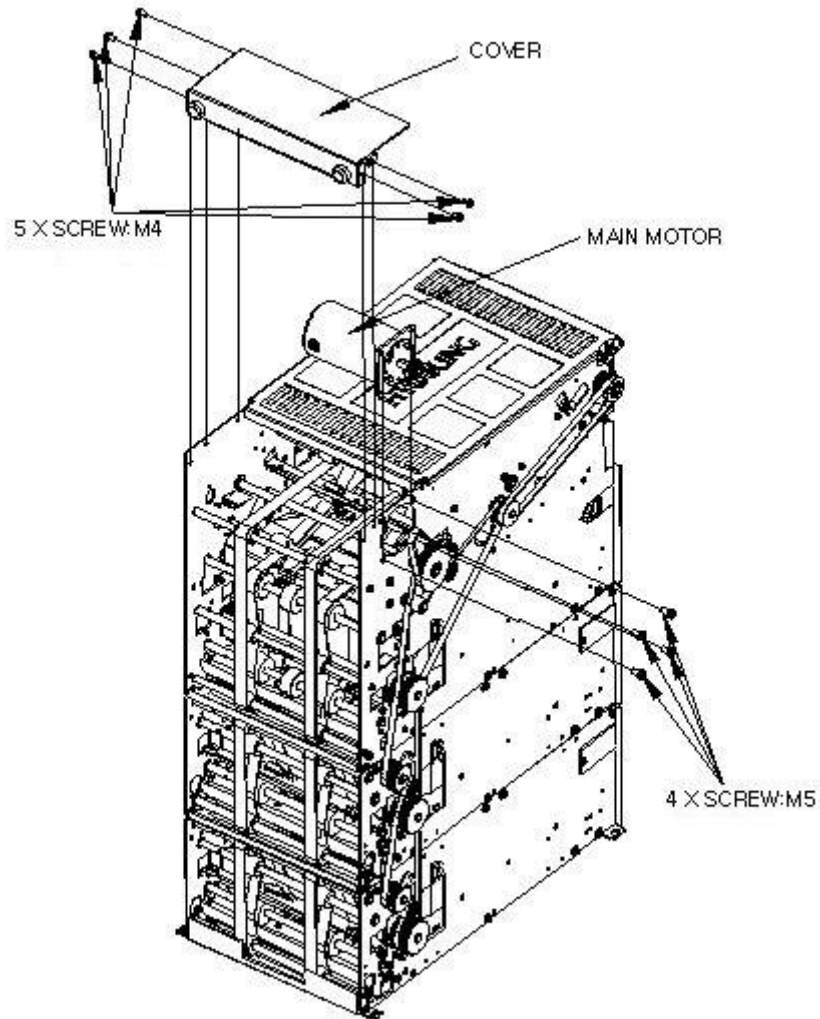

► Gate Solenoid Assembly

1. Remove the solenoid power cable.
2. Remove the $\phi 2$ E-ring.
3. Unscrew the solenoid bracket screws (M4, 2 places).
4. Unscrew the solenoid fixing screws (M4, 4 places).
5. Assemble in the reverse order – 4 ~1 after replacing a solenoid assembly. Adjust the gate according to the standard.

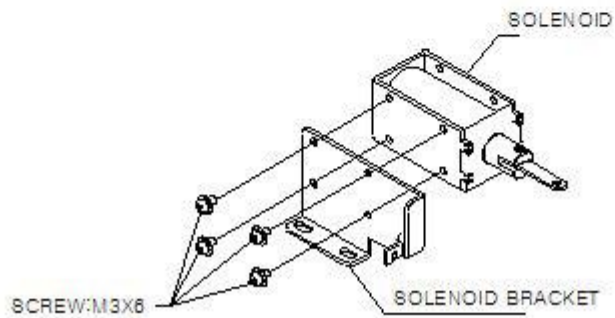
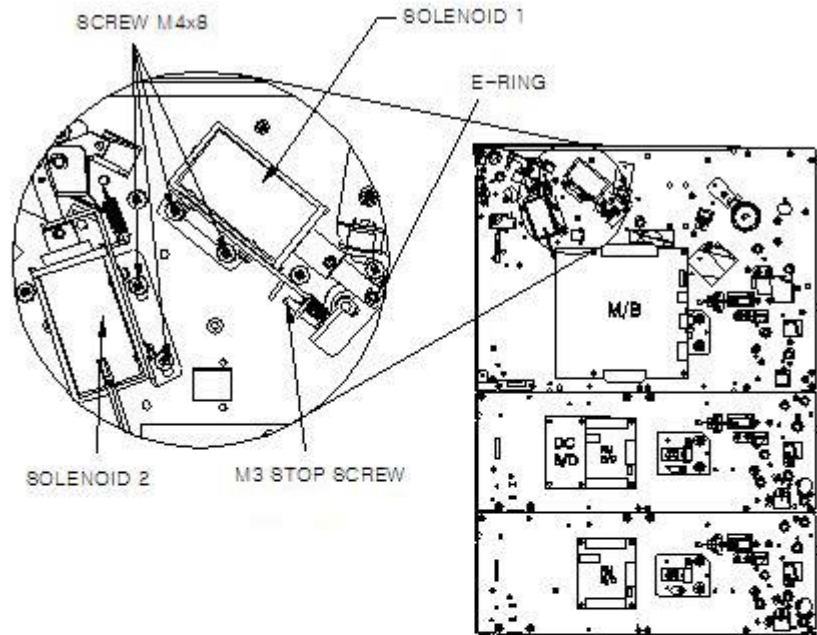

► Clutch Assembly

1. The clutch assembly is composed of three clutches as shown in the figure below.

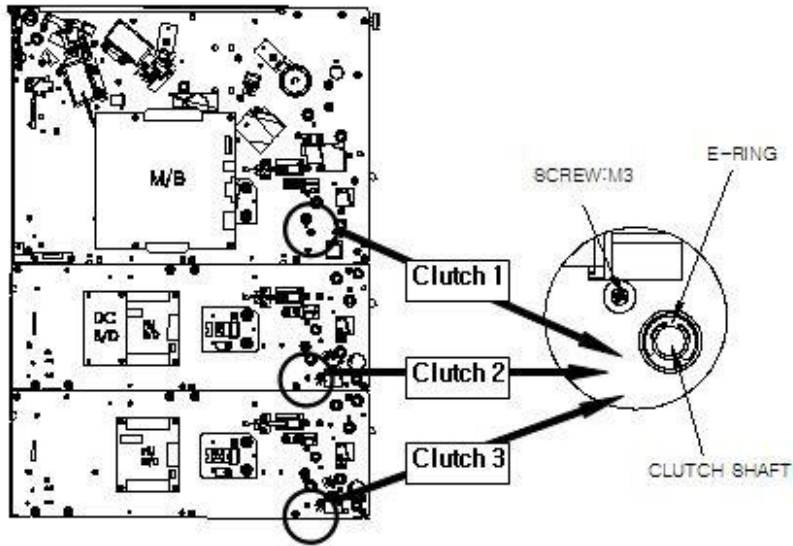

2. Remove the M4 screw (1 pace) and E-Ring to remove the clutch as shown in the above figure. Then, remove the M4 screws (3 places) as shown in the figure below.

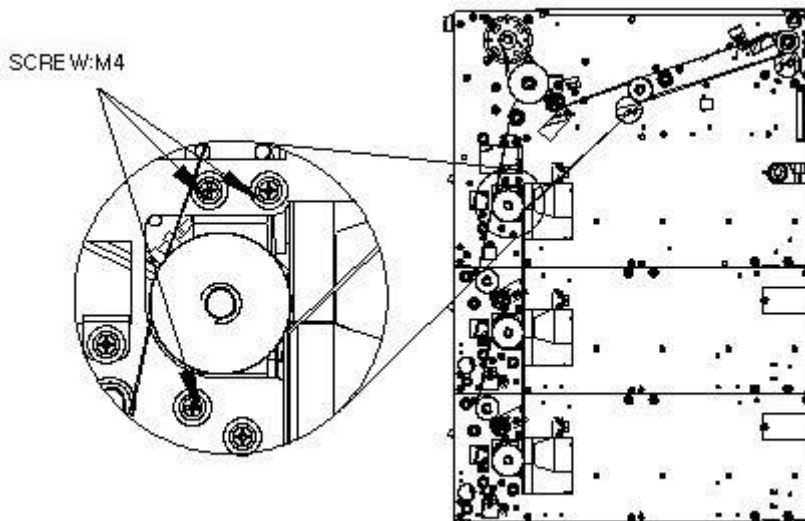

3. Remove the clutch assembly.

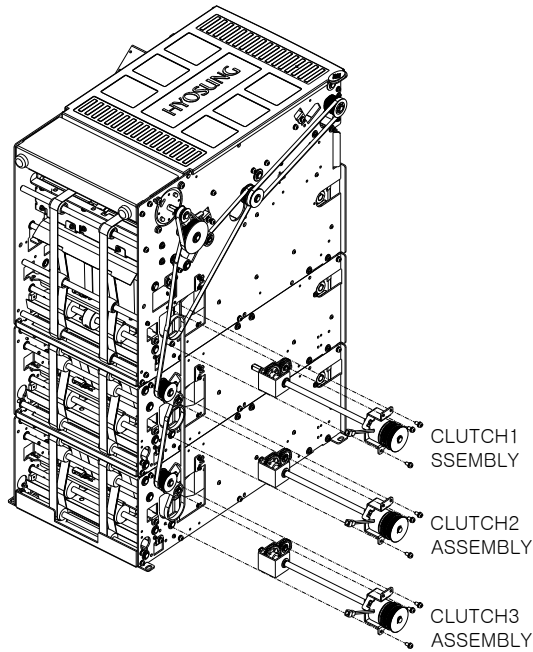

4. Replace the clutch assembly and assemble in the reverse order - 4 ~ 1.

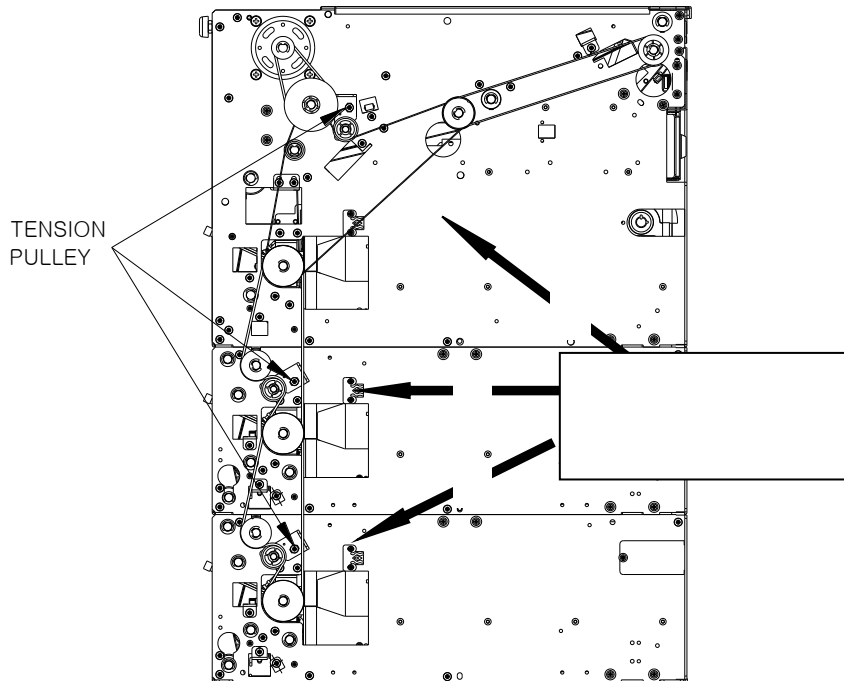

<Note!>

When replacing the clutch assembly, adjust the tension pulley so that belt tension is about 100g to the direction and about 200g ~ 300g to the direction when the timing belt is pressed by about 3mm (use the tension gauge).

Adjustment Standard

► Gate Adjustment

1. Loosen the solenoid M4 screw (2 places) as much as possible.

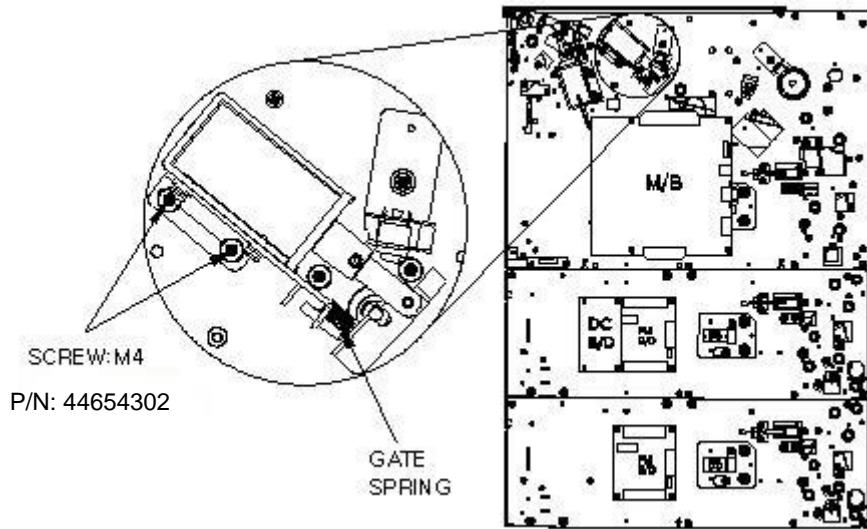

2. Adjust the solenoid position so that the gate is at least 1.5mm away from the shaft when you pull the gate as shown in the below right figure.
3. Adjust the solenoid position so that the gate is 1.5mm away from the shaft, when pulling the gate as shown in the right below figure.

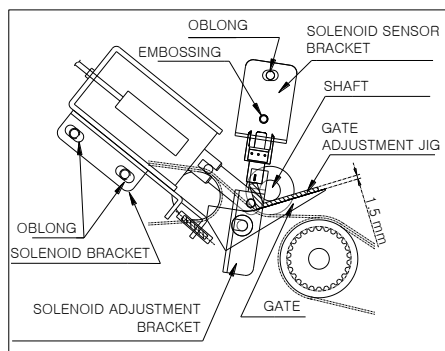

When the gate is pulled

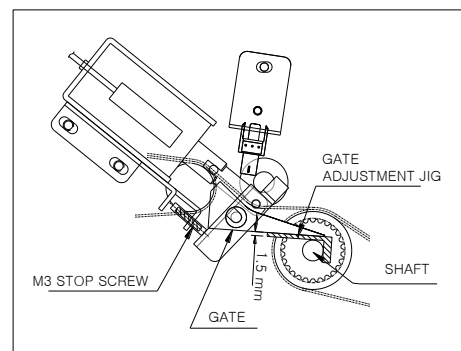

When the gate is released

4. Fix the solenoid M4 screws (2 places).

▶ Adjusting Gate2

1. Unscrew the solenoid bracket fixing M4 screws (2 places) by half.
2. Adjust the solenoid position so that the Gate2 is 3-4mm away from the CS3 sensor supporter when you pull the gate as shown in the figure below. Then, fasten the solenoid bracket fixing screws completely.

<Note!> Adjust distance between the supporter and Gate2 more than 3mm when the solenoid is released, as shown in the figure below.

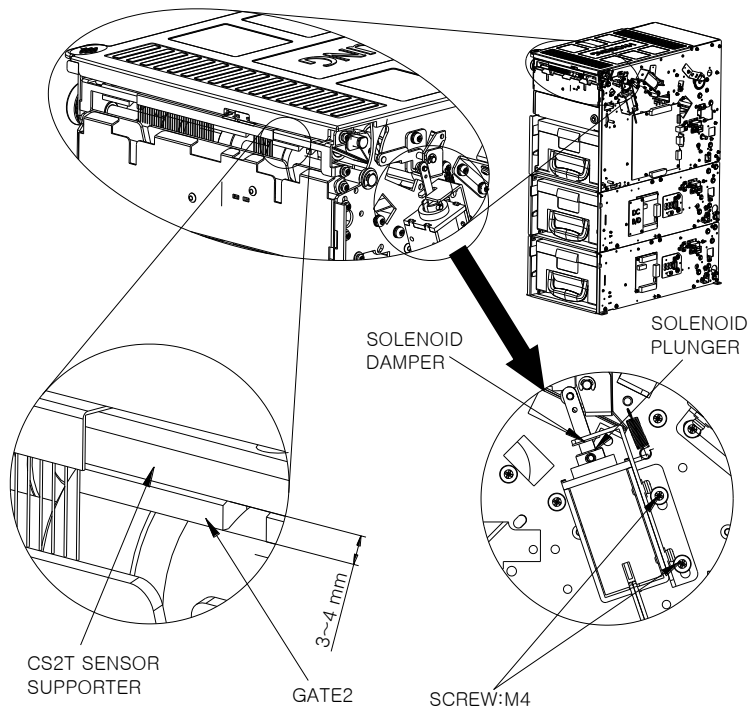

<When Solenoid is Pulled>

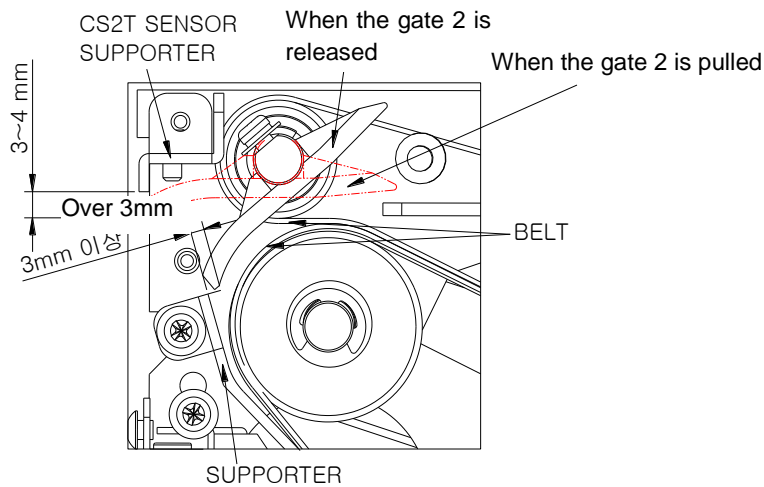

< When Solenoid is Released>

Oiling Standard

► Y1: Once a year, Warning: Be careful not to contaminate the belt with lubricant

| Location | Lubricants | Interval | Remark |
|---|--------------------|----------------|--|
| Tension Pulley | Mobil (1) | Y1 | Lubricate the friction part between the shaft and the pulley |
| Gate bush | Mobil (1) | Y1 | Lubricate the friction part between the bush and the gate shaft (2 places) |
| Gear support gear teeth surface | Albania Grease EP1 | Initial Oiling | - |
| Gate spring hook | Albania Grease EP1 | Initial Oiling | - |
| Gear support spring hook | Albania Grease EP1 | Initial Oiling | - |
| Note separate assembly gear teeth surface | Albania Grease EP1 | Initial Oiling | - |

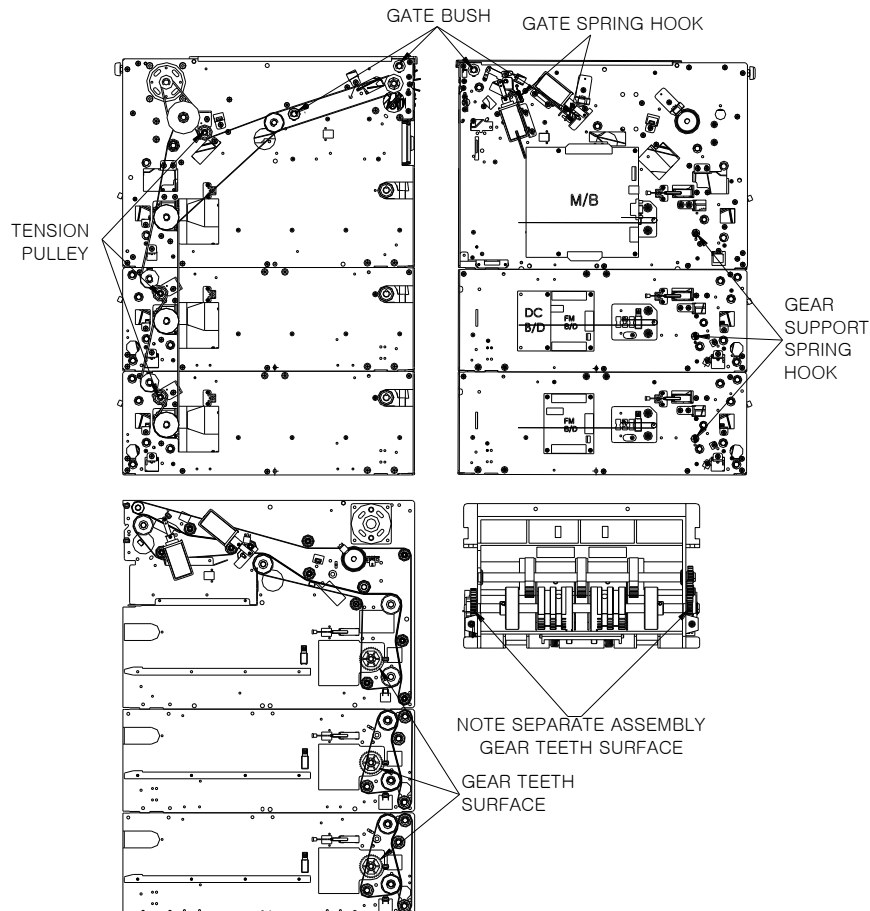

Cleaning Standard

- M6: Once every 6 months, M3: Once every 3 months.

| | Location | Int. | Remark |
|------------------------|--|------|--|
| CDU Main Body | CS1(A,B)D,T / CS15(A,B)D,T CS31(A,B)D,T / CS4(A,B)D,T CS2D,T / CS13D,T CS3 / CS8 CS7 / CS7 / CS17 CS6 / CS16 / CS26 Guide entrance | M6 | Remove the foreign objects and dust using a soft brush |
| Note separate ASS'Y | Roller | M3 | Remove the foreign objects and dust using a soft brush |

Setting Specifications

► Dip S/W Specifications

1. CN7 (Refer to the cable connection diagram)

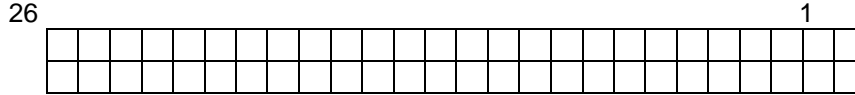

| S1 | Setting | Comments |
|-------------|---------|-------------------------------|
| #1, #2, #12 | Short | Forced EP Download, Test mode |
| #1, #2 | Short | Test mode |
| #1~#26 | Open | AP mode |

2. CN7 Default setting

#1~#26 Open

3. FM B/D DIP S/W Specifications

| FM B/D | DIP S/W | Remark |
|------------|-----------------|---------|
| 2 CASSETTE | #1, #6, #7 : ON | Default |
| 3 CASSETTE | #2, #4, #6 : ON | Default |

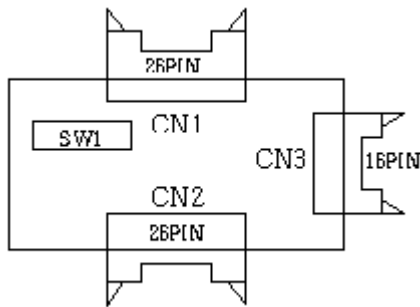

(Mounting 2 Cassettes)

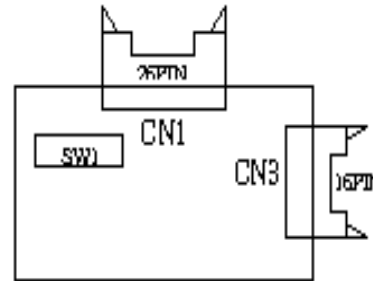

(Mounting 3 Cassettes)

Cable Connection Diagram

► Main Board

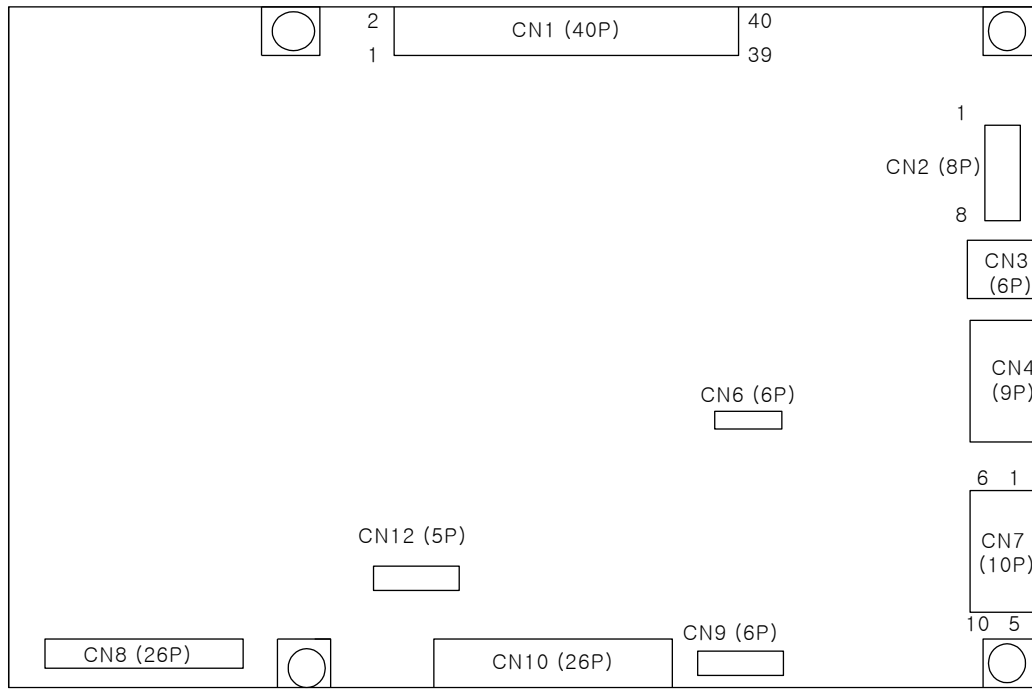

| Seq | Connector Name | No. of Pins | Use |
|-----|----------------|-------------|------------------------------|
| 1 | CN1 | 40 | Sensor Unit |
| 2 | CN2 | 8 | Motor, Clutch, Solenoid |
| 3 | CN3 | 6 | Additional Sensor Unit |
| 4 | CN4 | 9 | RS-232C Comm. |
| 5 | CN6 | 6 | PLD Download |
| 6 | CN7 | 10 | POWER (VCC, +12V, +24V, GND) |
| 7 | CN8 | 26 | DIP S/W signal |
| 8 | CN9 | 6 | DC/DC Power Unit |
| 9 | CN10 | 26 | FM B/D Connection Unit |
| 10 | CN12 | 5 | 2 Sheet I/F |

CDU21

Overview

► Appearance & Dimension

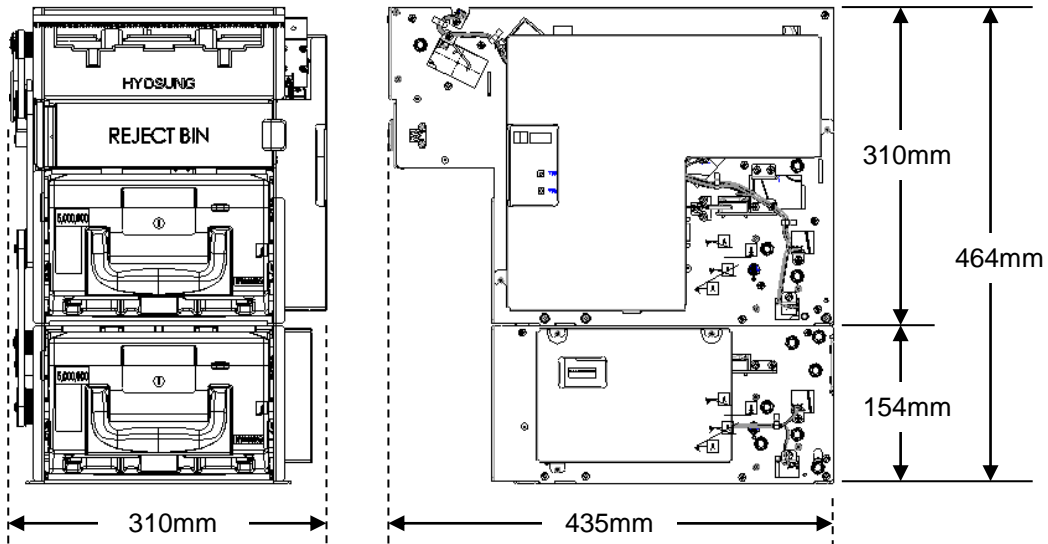
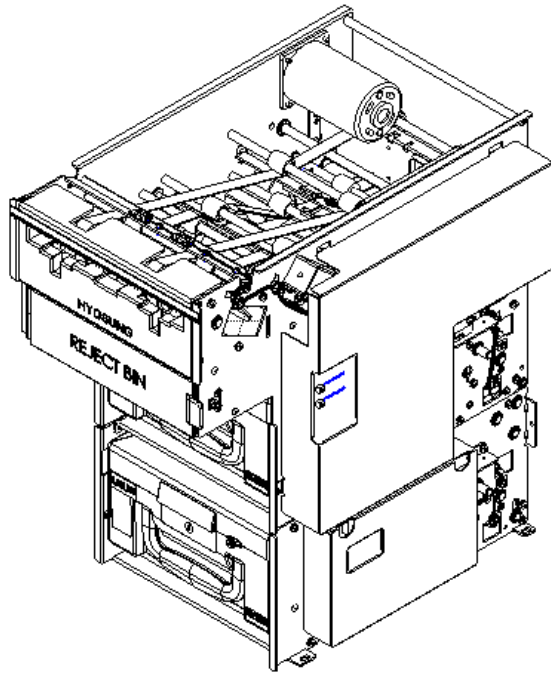

▶ Device Configuration

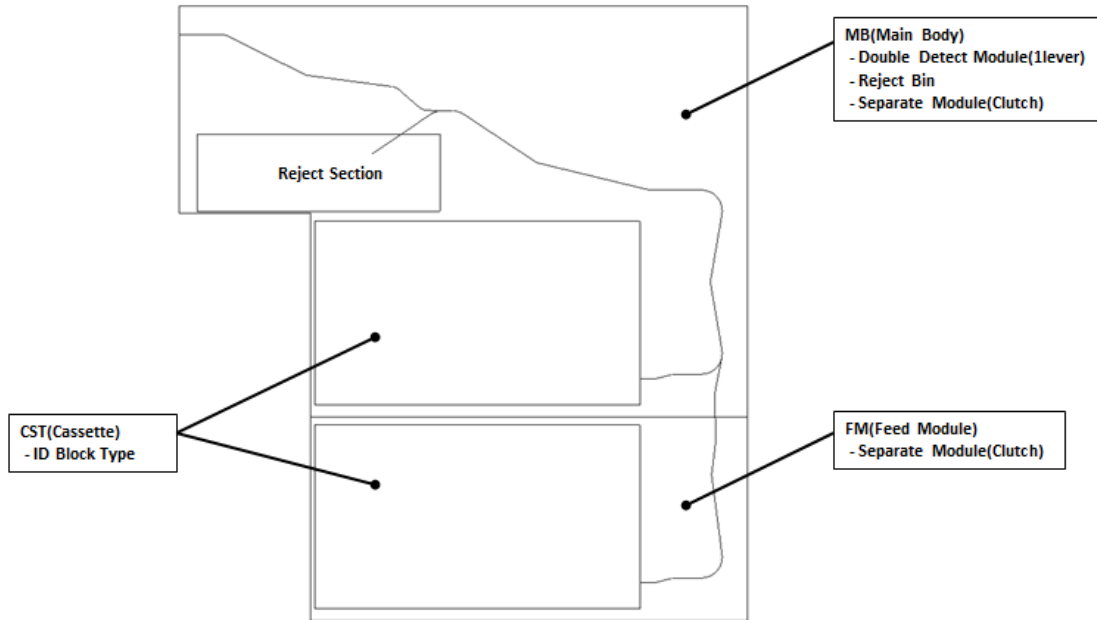

▶ Device Configuration Module

| Module | Description |
|---------------------------|---|
| Separate Module (Clutch) | When dispensing the notes, deliver the motive power to the cassette to separate the notes. Then after separation, release the motive power. |
| Double Bill Detect Module | Detect the thickness of the separated note and if it is more than 2 notes, obtain the data to make the notes rejected. |
| Cassette | Admit up to 1,000 notes and contain the separation section (partial roller structure of overlap method). |
| Reject Section | After checking the length, interval, skew, and thickness of the separated notes, keep the N.G notes. |

► Specification

| Item | | Specification | Remarks |
|---------------------|-------------------------|---|--------------------------------------|
| External Appearance | Dimension | 310(W)x464(H)x435(D)mm (12.20x18.27x17.13inch) | |
| Weight | Weight of the main body | 15kg(33.07lb) | |
| | Weight of the cassette | Empty (2.37kg(5.22lb)) / Full (1,000notes) status (3.3kg(7.28lb)) | |
| Media | Denomination | USA / Canadian Dollar | |
| | Media Size (L x H) | USA - 156x66mm(6.1x2.6inch) Canada - 152.4x70mm(6.0x2.8inch) | |
| | Thickness | 0.09 ~ 0.11mm (0.0035~0.0043inch) | |
| Dispensing | Shutter Yes/No | No | Tray outside the main body |
| | Dispensing Speed | 4 notes/sec | |
| | Maximum number | 40 notes/transaction | |
| Separation | Separation Type | Friction Type | |
| Reject | Capacity | 58 mm | About 200 notes based on new notes |
| | Security | No Key | |
| | Quantity Detection | No | Software Count |
| Cassette | Capacity | 123 mm | About 1,000 notes based on new notes |
| | Loading Direction | Front Access | |
| | Detecting Remnants | No | |

Disassembly & Reassembly

Module Disassembly

► Disassembly of Main Body and Feed Module

1. Turn off the power before disassembly.
2. Remove Cassettes.

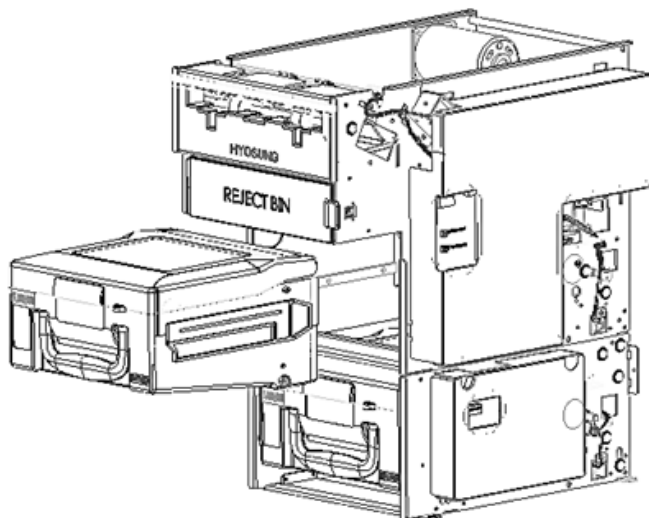

3. Remove 2 screws (①) and disassemble main cover (②).

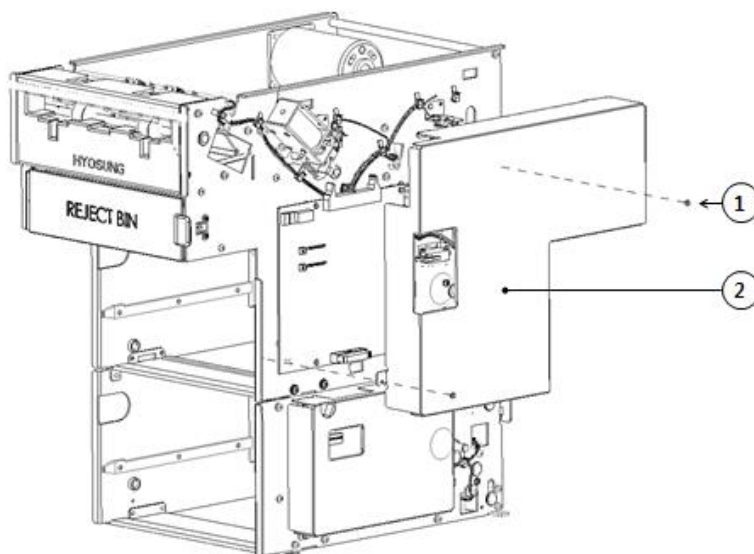

3. Disconnect the cable connector CN10 (③)

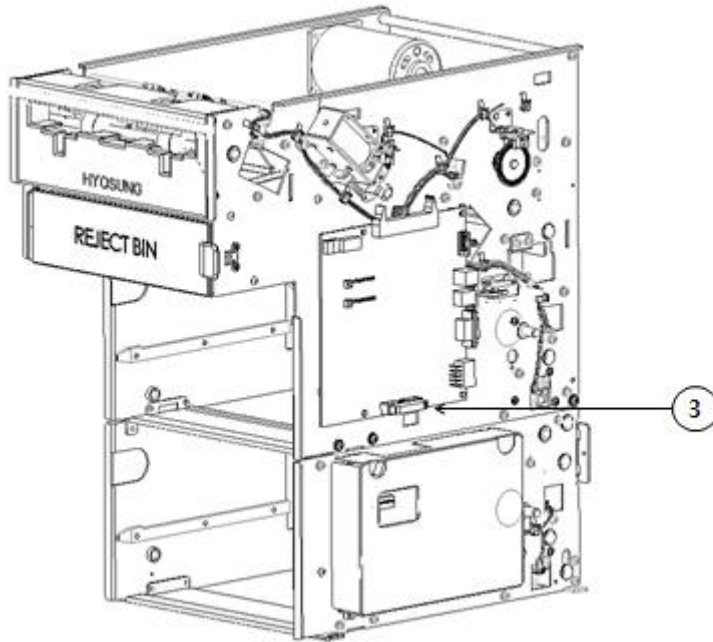

4. Release the M4 screw (④) to remove the timing belt (⑤).

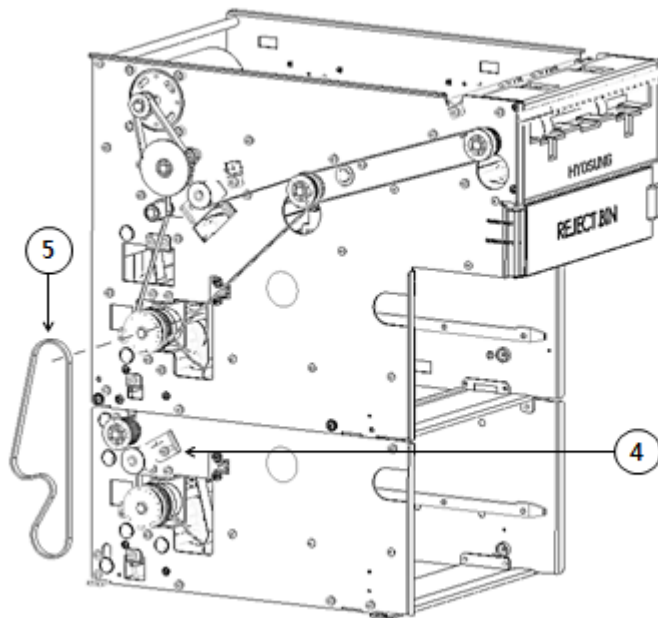

5. Remove 8 green screws (⑥x6, ⑦x2).

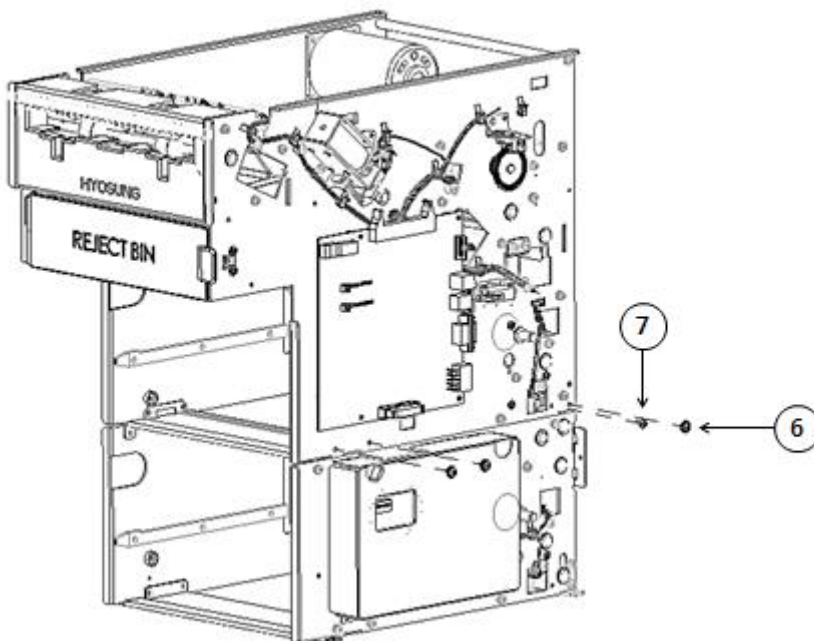

6. Separate MB module and FM module.

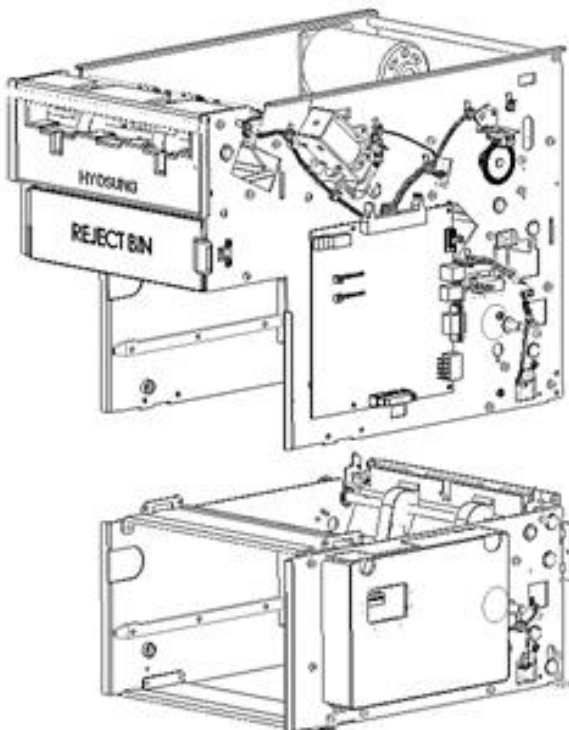

► Disassembly of Double Bill Detection Section

1. Disassemble the main cover. (Refer to Disassembly of MB and FM)
2. Disconnect the cable connector CS5.

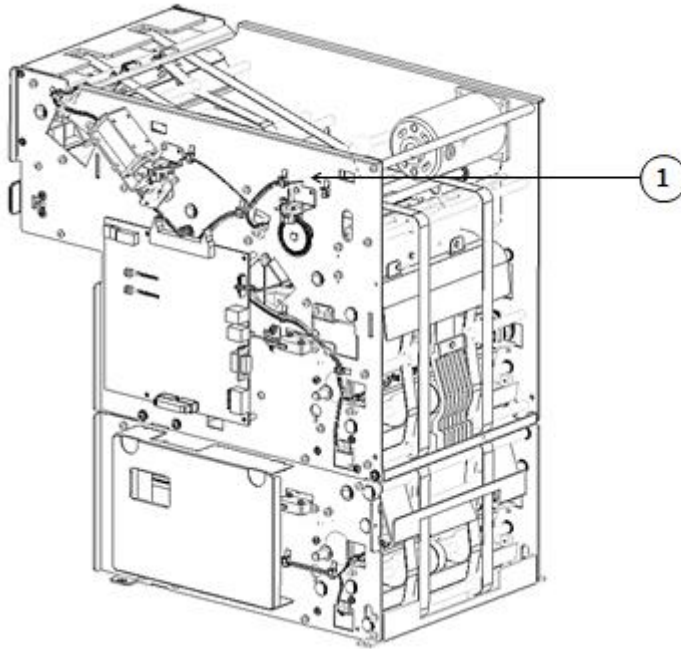

3. Remove M4 screws. (4 places)

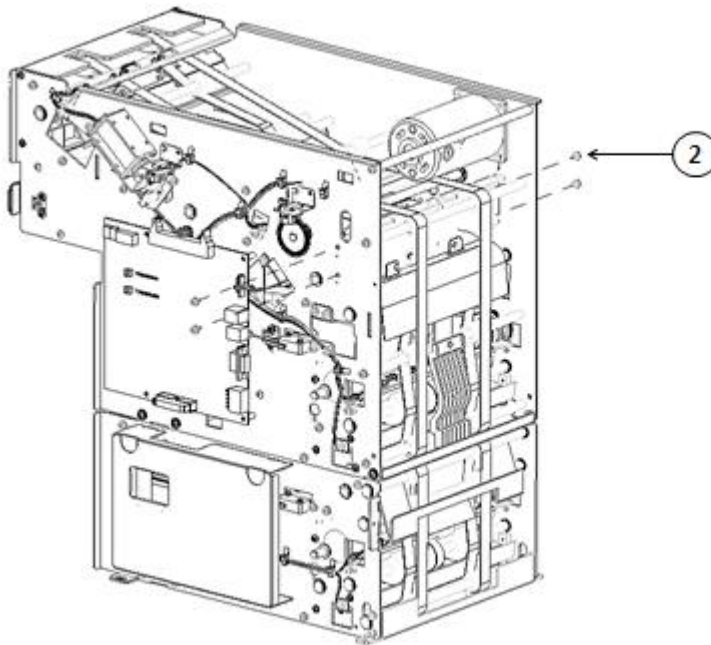

4. Disassemble the double detect sensor module.

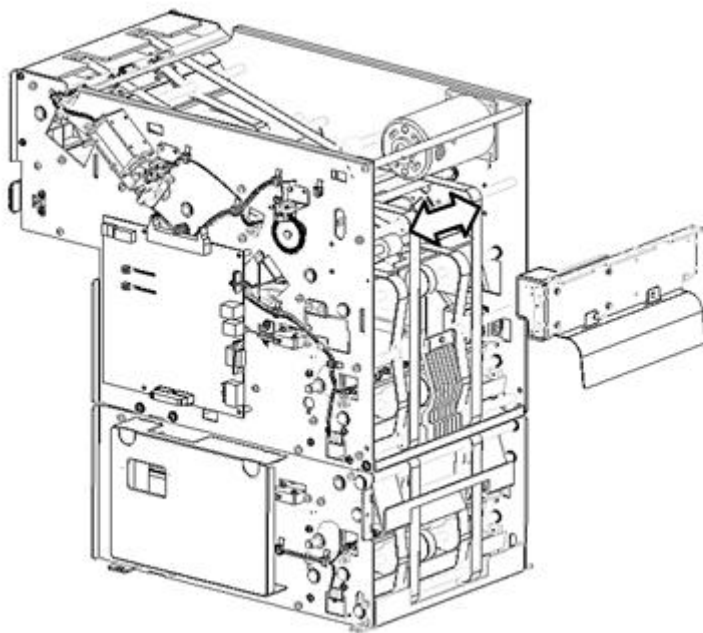

Electronic Parts Disassembly

PCBA Disassembly

▶ Main Board Disassembly

1. Disassemble the main cover. (Refer to Module Disassembly)
2. Disconnect the cable assembly. (CN1, CN2, CN10)
3. Remove 4 screws (②) and disassemble main board.

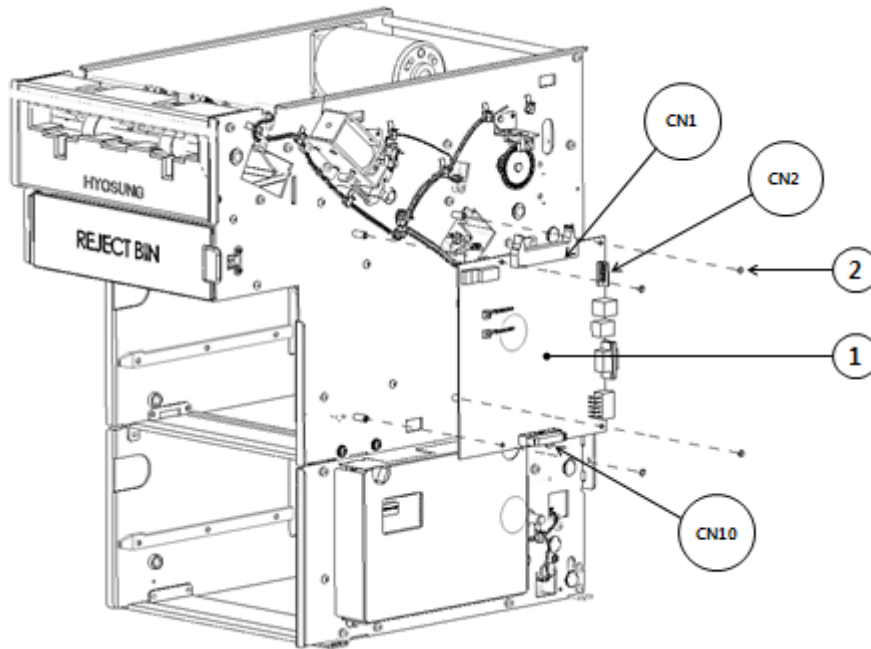

4. To assemble again, use the reverse order of disassembly.

► FM Board Disassembly

1. Disassemble the main cover. (Refer to Module Disassembly)
2. Disassemble the FM cover.

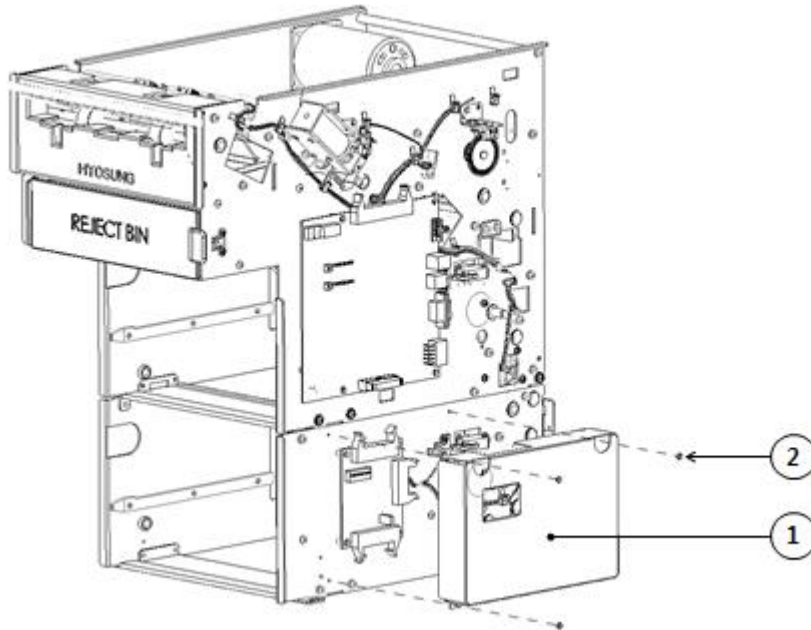

3. Disconnect the cable assembly. (CN1, CN3, CN4)
4. Remove 4 screws (④) and disassemble FM Board.

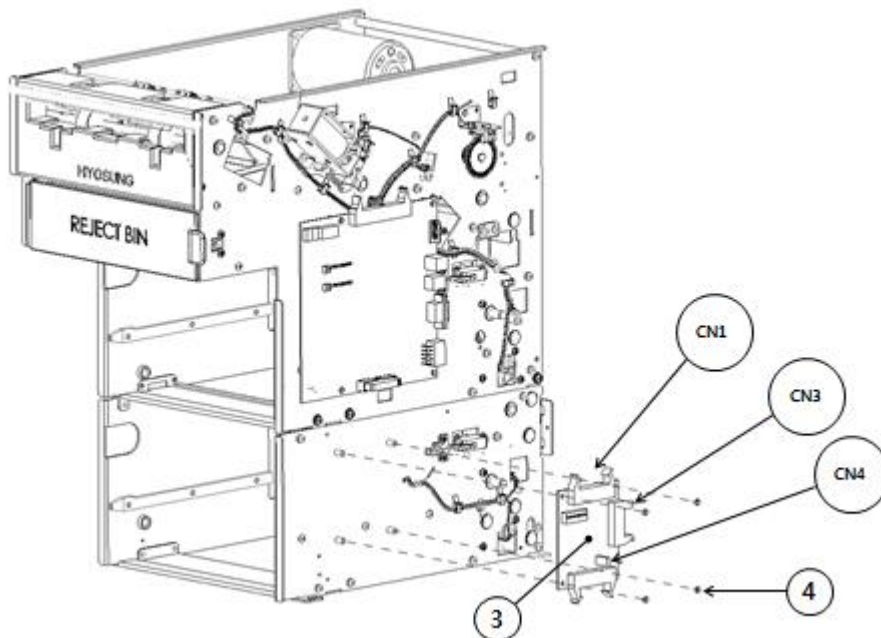

5. To assemble again, use the reverse order of disassembly.

Sensor Disassembly

► Location Map of Sensor

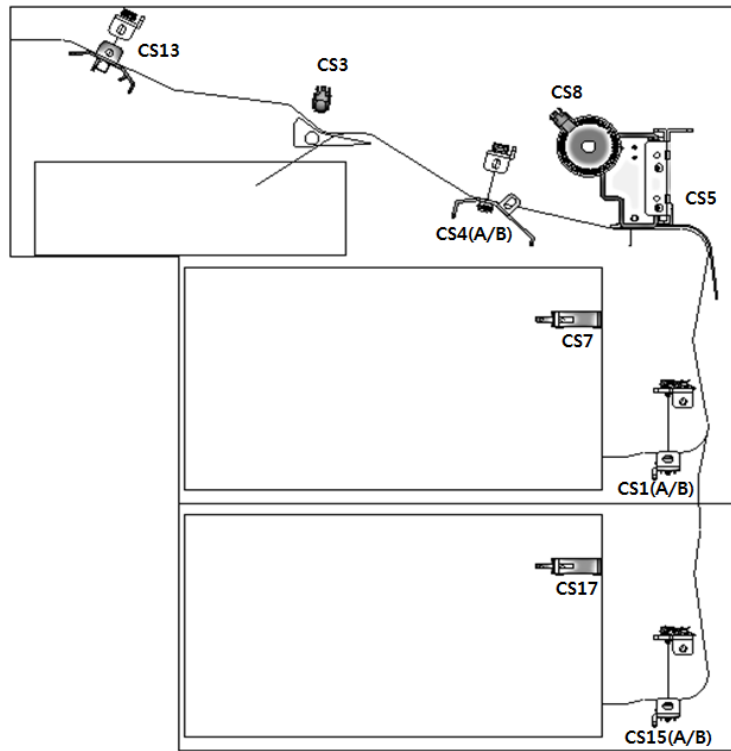

<Note!>

A = Sensor far from the board.
B = Sensor close to the board.

► Disassembly of Separated Type Sensor.

1) CS1D(A/B), CS15D(A/B)

1. Disassemble the main cover. (CS1D(A/B), Refer to Module Disassembly)
Or disassemble the FM cover. (CS15D(A/B), Refer to FM Board Disassembly)
2. Remove the M4 screws (2 places each) as shown in the figure below.
3. Remove the connector and the cable tie to remove the sensor bracket.
(Be careful not to break the connector pin when removing.)
4. Remove the sensor bracket.
5. From the removed sensor bracket, remove the M3 screw of the sensor which will be replaced.
6. Replace the sensor.
7. Assemble the unit in the reverse order - 5~1.

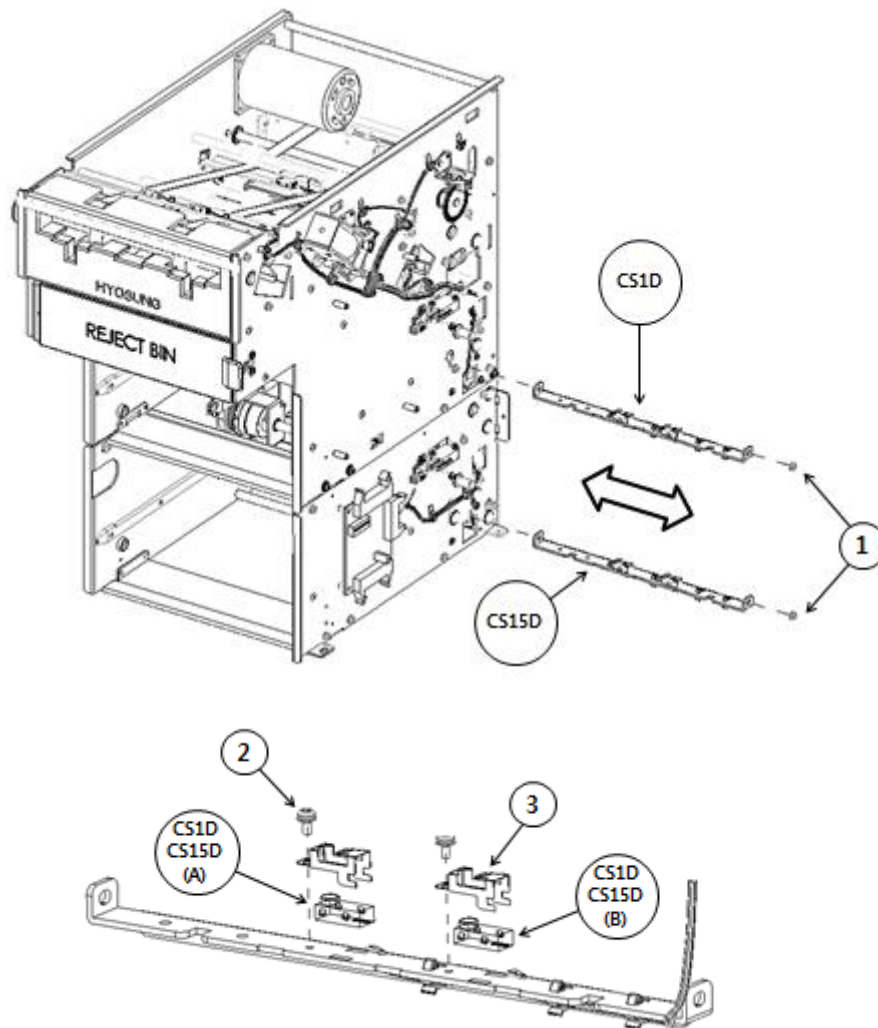

2) CS1T(A/B), CS15T(A/B)

1. Disassemble the main cover. (CS1T(A/B), Refer to Module Disassembly)
Or disassemble the FM cover. (CS15T(A/B), Refer to FM Board Disassembly)
2. Remove the M4 screws (2 places each) as shown in the figure below.
3. Remove the connector and the cable tie to remove the sensor bracket.
(Be careful not to break the connector pin when removing.)
4. Remove the sensor bracket.
5. From the removed sensor bracket, remove the M3 screw of the sensor which will be replaced.
6. Replace the sensor.
7. Assemble the unit in the reverse order - 5~1.

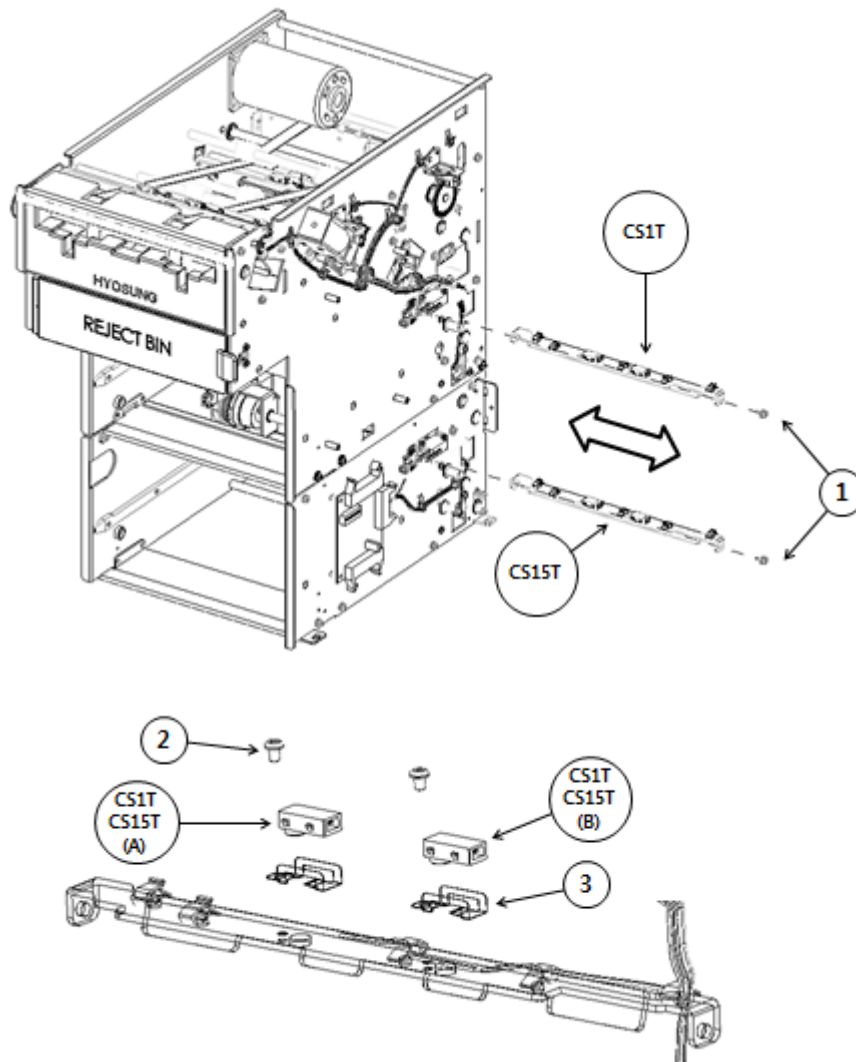

3) CS4D(A/B)

1. Disassemble the main cover. (Refer to Module Disassembly)
2. Disassemble the main board. (Refer to PCBA Disassembly)
3. Remove the M4 screws (2 places) as shown in the figure below.
4. Remove the connector and the cable tie to remove the sensor bracket.
(Be careful not to break the connector pin when removing.)
5. Remove the sensor bracket.
6. From the removed sensor bracket, remove the M3 screw of the sensor which will be replaced.
7. Replace the sensor.
8. Assemble the unit in the reverse order - 6~1.

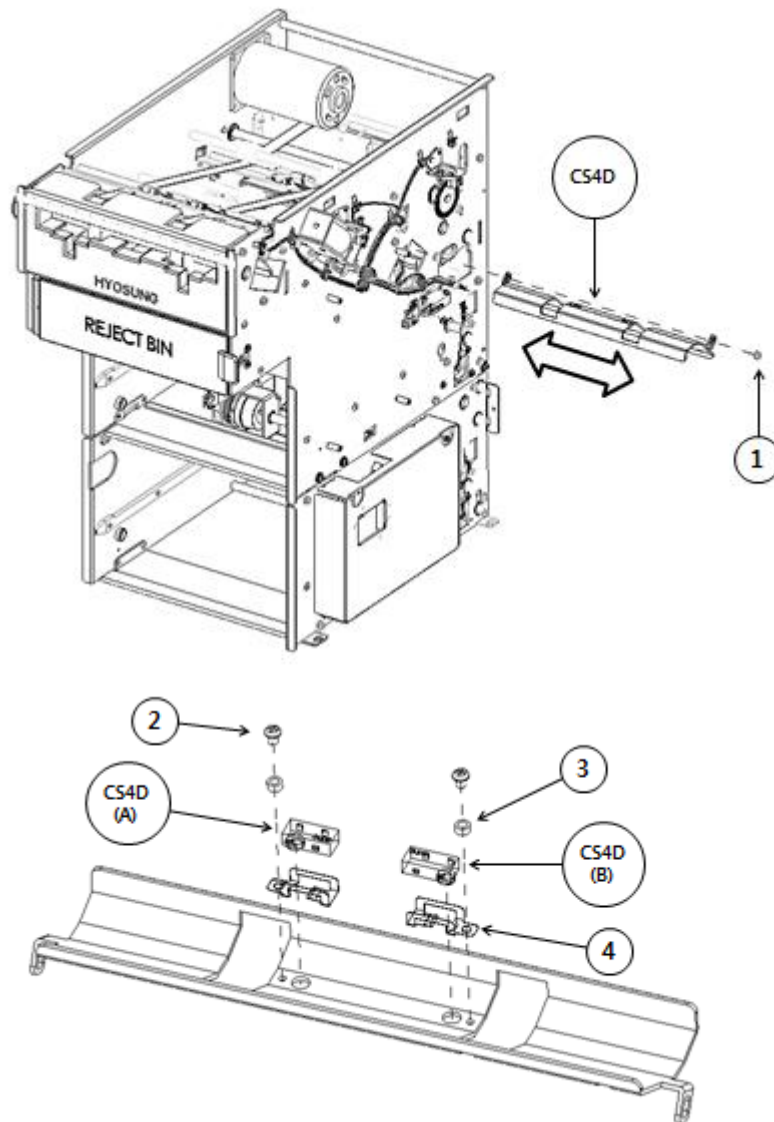

4) CS4T(A/B)

1. Disassemble the main cover. (Refer to Module Disassembly)
2. Remove the M4 screws (2 places) as shown in the figure below.
3. Remove the connector and the cable tie to remove the sensor bracket.
(Be careful not to break the connector pin when removing.)
4. Remove the sensor bracket.
5. From the removed sensor bracket, remove the M3 screw of the sensor which will be replaced.
6. Replace the sensor.
7. Assemble the unit in the reverse order - 5~1.

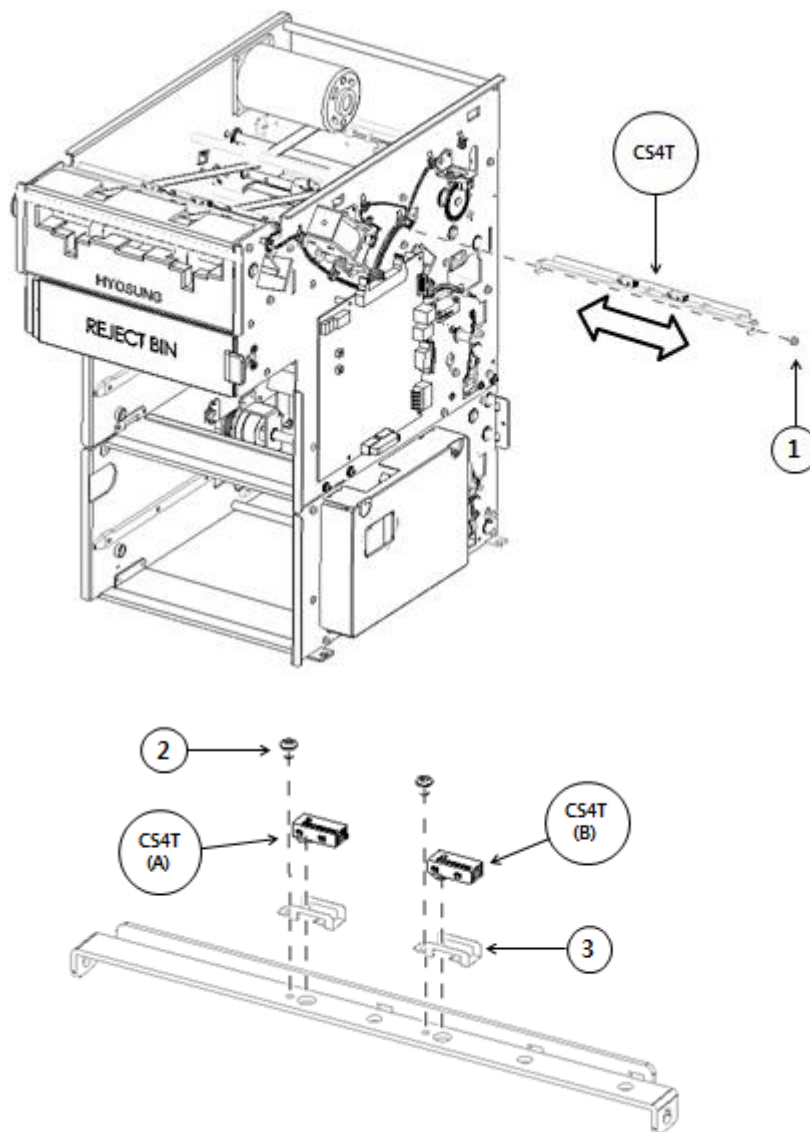

5) CS13

1. Disassemble the main cover. (Refer to Module Disassembly)
2. Remove the M4 screws (2 places) as shown in the figure below.
3. Remove the connector and the cable tie to remove the sensor bracket.
(Be careful not to break the connector pin when removing.)
4. Remove the sensor bracket.
5. From the removed sensor bracket, remove the M3 screw of the sensor which will be replaced.
6. Replace the sensor.
7. Assemble the unit in the reverse order - 5~1.

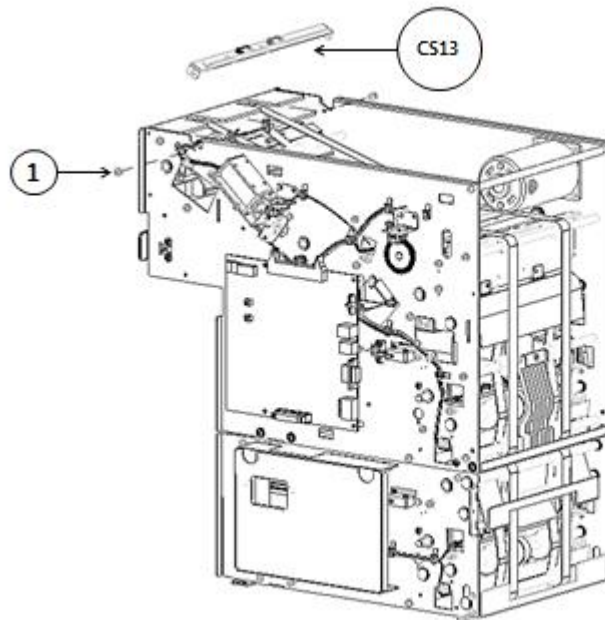

<Note!> Be sure to check the position of sensor and assemble it.
(Refer to figure below)

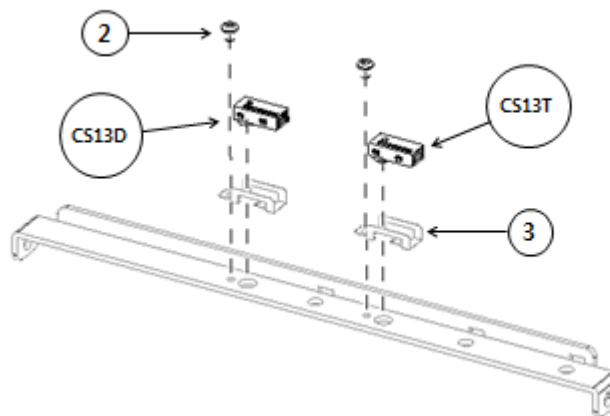

► Disassembly of Gate Operation Detection Sensor & Encoder Sensor

1) CS3 (Gate Operation Detection Sensor)

1. Disassemble the main cover. (Refer to Module Disassembly)
2. Remove the M3 screw of the CS3 sensor bracket.
3. Remove the connector and the cable tie to remove the sensor bracket.
(Be careful not to break the connector pin when removing.)
4. Remove the rubber ①.
5. Press the part② of the sensor gently as shown in the figure below to remove the lock and the sensor.
6. To insert the sensor, insert the part③ first, and then press part② to lock.
7. Assemble in the reverse order - 5~1.

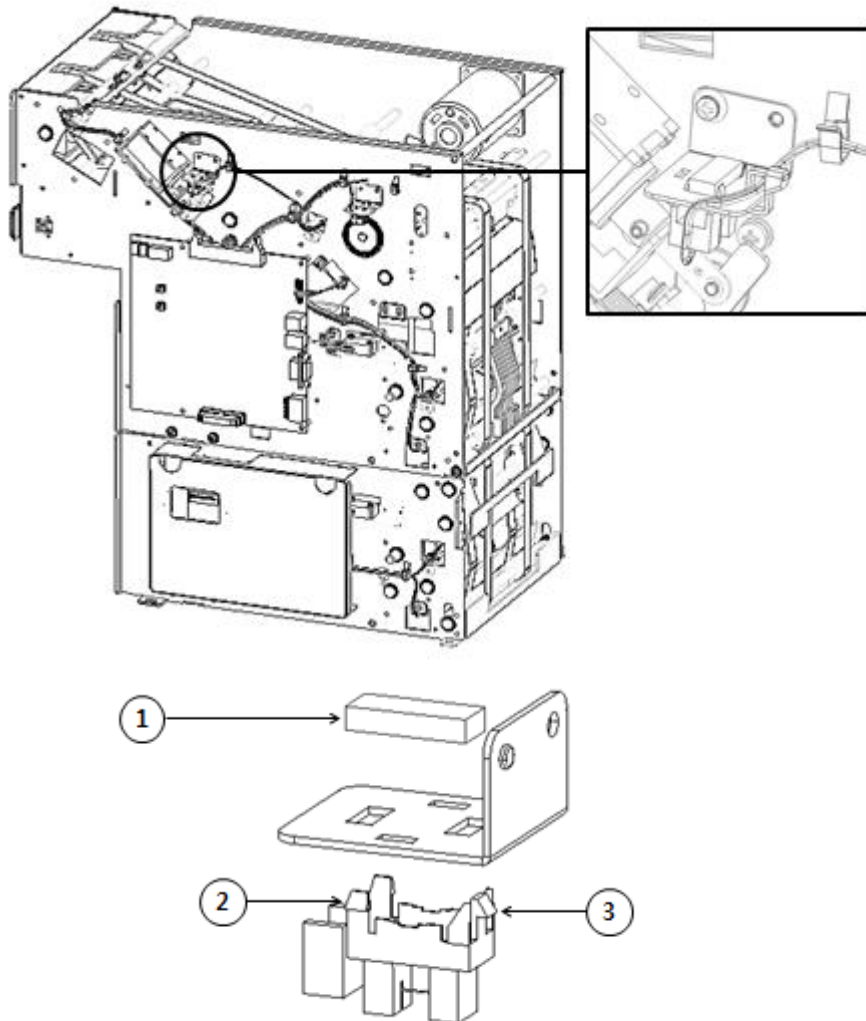

<Note!> When reassembling the CS3, pull the solenoid and adjust the detection bracket to the center of the sensor while the screw is still loose. Then, tighten the screw.

1) CS8 (Encoder Sensor)

1. Disassemble the main cover. (Refer to Module Disassembly)
2. Remove the M3 screw of the CS8 sensor bracket.
3. Remove the connector and the cable tie to remove the sensor bracket.
(Be careful not to break the connector pin when removing.)
4. Remove the rubber ①.
5. Press the part② of the sensor gently as shown in the figure below to remove the lock and the sensor.
6. To insert the sensor, insert the part③ first, and then press part② to lock.
7. Assemble in the reverse order - 5~1.

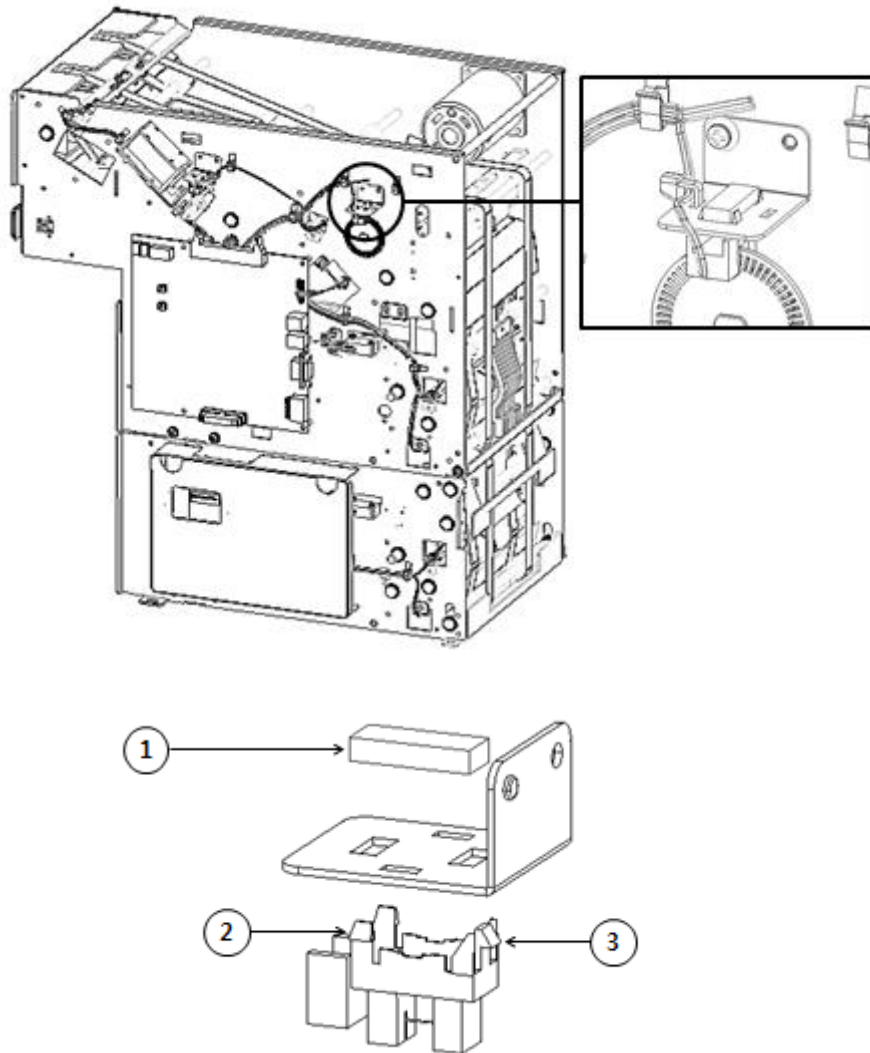

► Disassembly of CST Position Check Sensor

1) CS7, CS17

1. Disassemble the main cover. (CS7, Refer to Module Disassembly)
Or disassemble the FM cover. (CS17, Refer to FM Board Disassembly)
2. Remove the sensor bracket M4 screws (2 places each).
3. Remove the connector and the cable tie to remove the sensor bracket.
(Be careful not to break the connector pin when removing.)
4. Remove the sensor bracket.
5. Remove the M3 screws (2 places each) from the removed sensor bracket.
6. Replace the sensor.
7. Assemble the unit in the reverse order - 5~1.

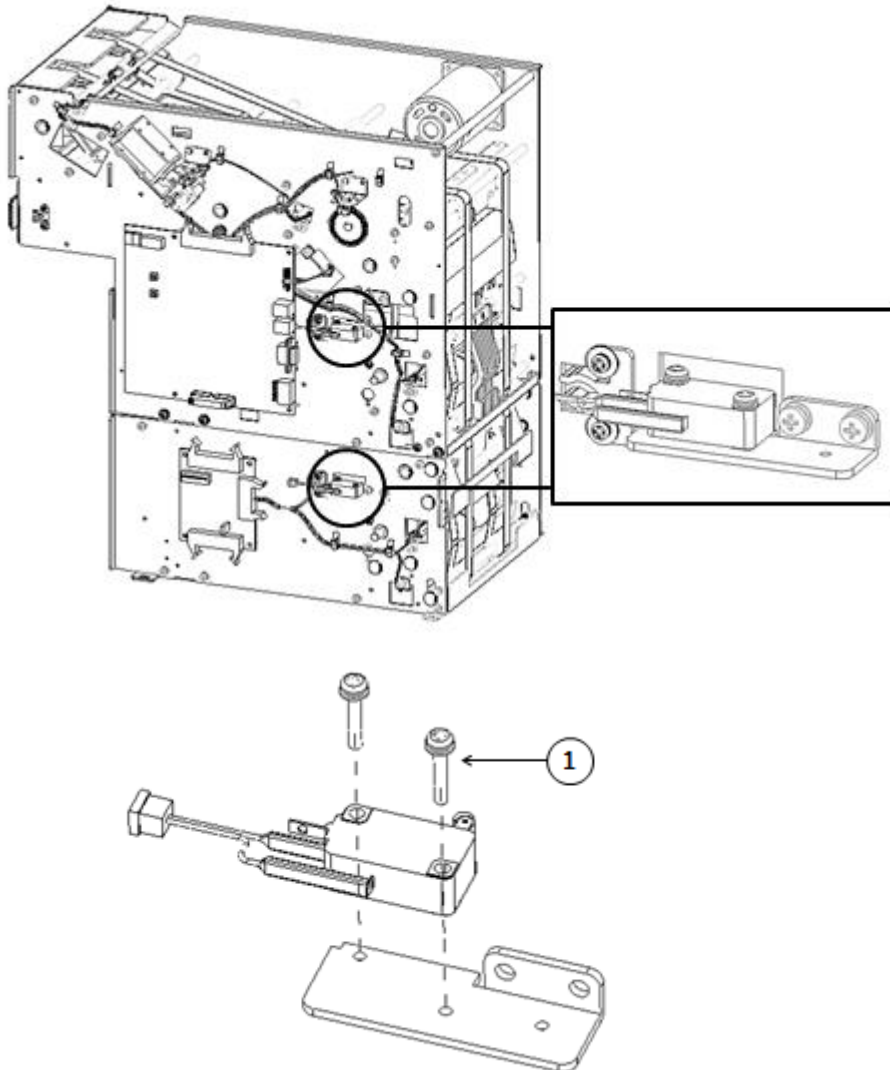

<Note!> Adjust the cassette position when mounting it until a click sound is heard.

Actuator Disassembly

► Motor Disassembly

1. Disconnect the cable (M1), then remove 4 screws (①) and disassemble Motor (②)

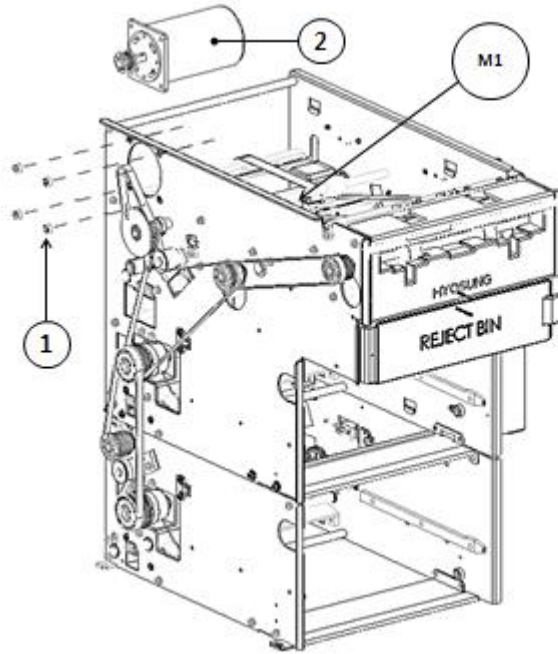

2. Disassemble GEAR (③) and E-RING (④) from Assy Motor.

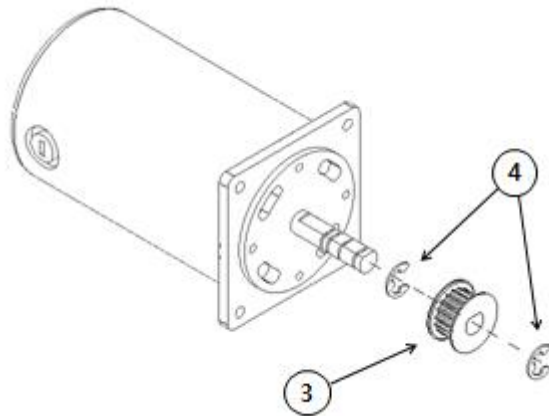

3. To assemble again, use the reverse order of disassembly.

► Solenoid Disassembly

1. Disassemble the main cover. (Refer to Module Disassembly)
2. Disconnect the cable. (S1)
3. Disassemble e-ring (2) connected to solenoid and bracket.
Then disassemble solenoid assembly.

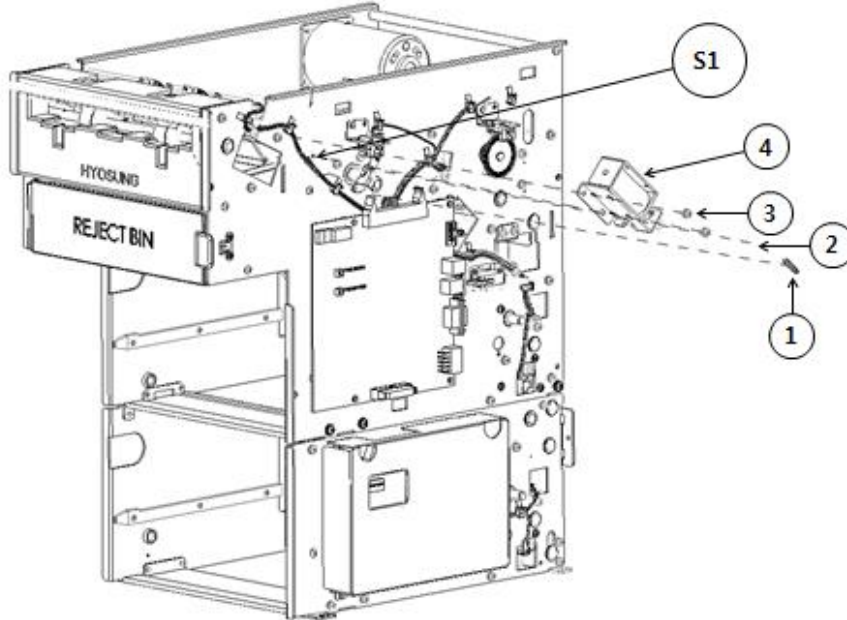

4. Disassemble the solenoid from Solenoid assembly.

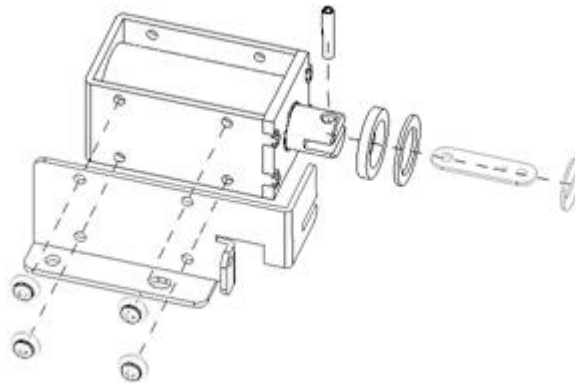

5. To assemble again, use the reverse order of disassembly.

<Note!> Be careful not to miss the rubber damper.

<Note!> Check the gap between gate and shaft.

The gate is at least 1.5mm away from the shaft when you pull or release the gate as shown in the below figure.

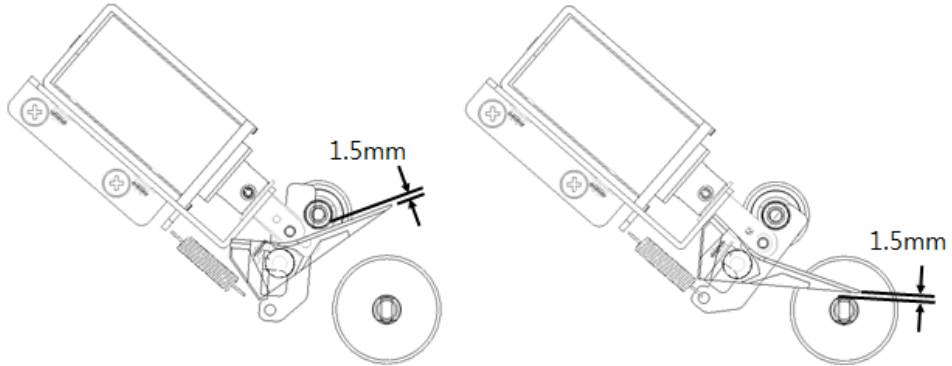

When the gate is pulled

When the gate is released

If there is no gap, please adjust the gate position

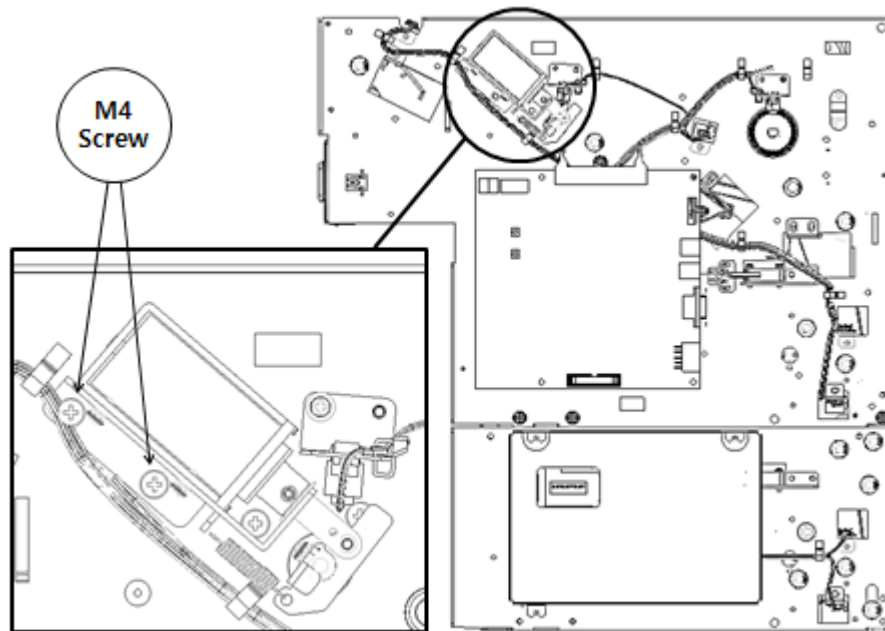

► Clutch Assembly

1. Adjust the tension pulley to loosen the timing belts

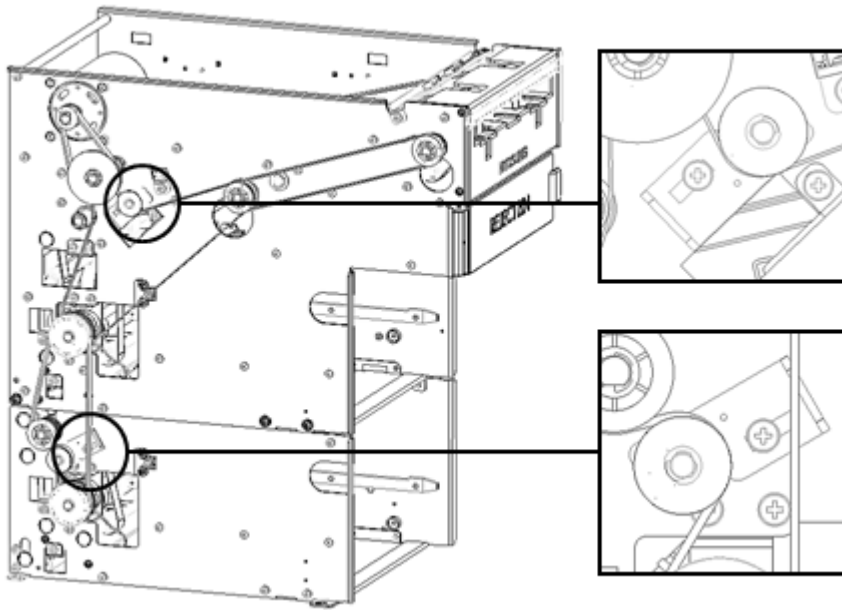

2. Remove the spring and e-ring to remove the clutch.

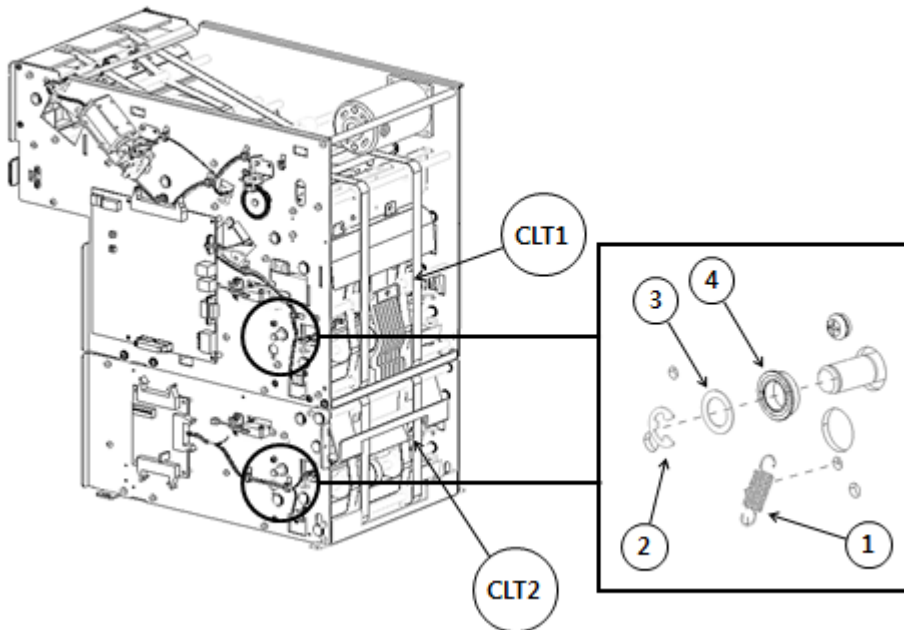

3. Remove the M4 screws. (3 places each)

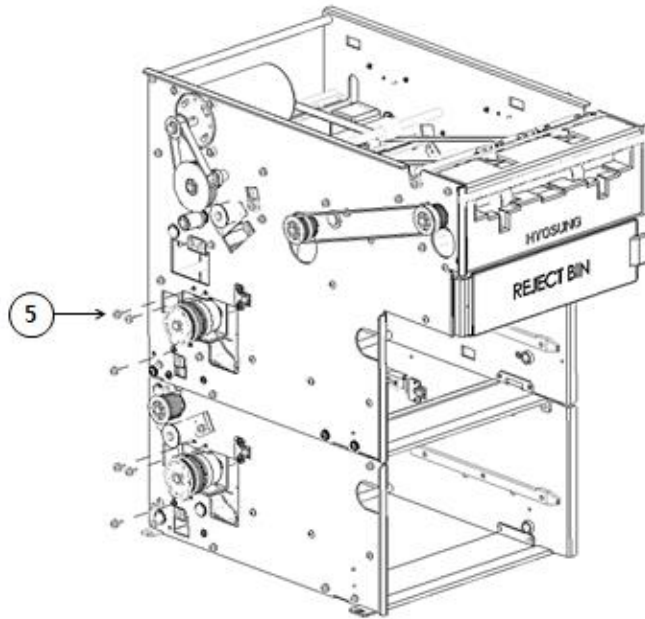

4. Remove the clutch assembly.

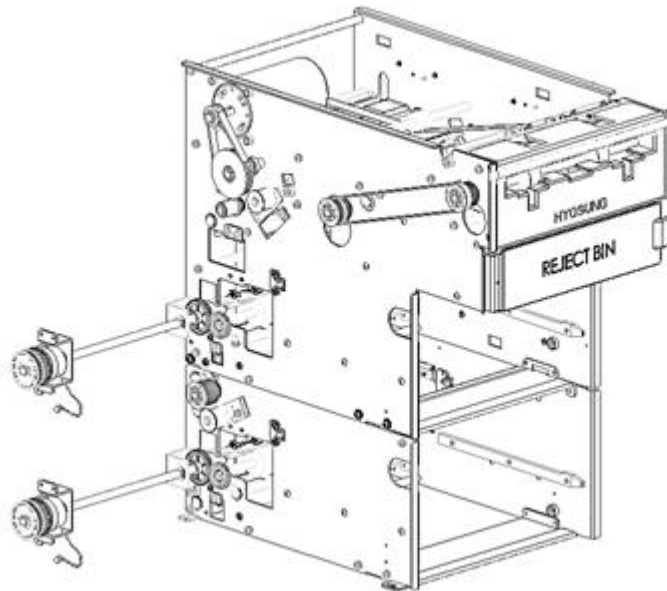

5. To assemble again, use the reverse order of disassembly.

<Note!>

When replacing the clutch assembly, adjust the tension pulley so that belt tension is about 100g to the direction and about 200g ~ 300g to the direction when the timing belt is pressed by about 3mm (use the tension gauge).

Oiling Standard

► Y1: Once a year, [Warning : Be careful not to contaminate the belt with lubricant]

| Location | Lubricants | Interval | Remark |
|---|--------------------|----------------|--|
| Tension Pulley | Mobil (1) | Y1 | Lubricate the friction part between the shaft and the pulley |
| Gate bush | Mobil (1) | Y1 | Lubricate the friction part between the bush and the gate shaft (1 places) |
| Gear support gear teeth surface | Albania Grease EP1 | Initial Oiling | - |
| Gate spring hook | Albania Grease EP1 | Initial Oiling | - |
| Gear support spring hook | Albania Grease EP1 | Initial Oiling | - |
| Note separate assembly gear teeth surface | Albania Grease EP1 | Initial Oiling | - |

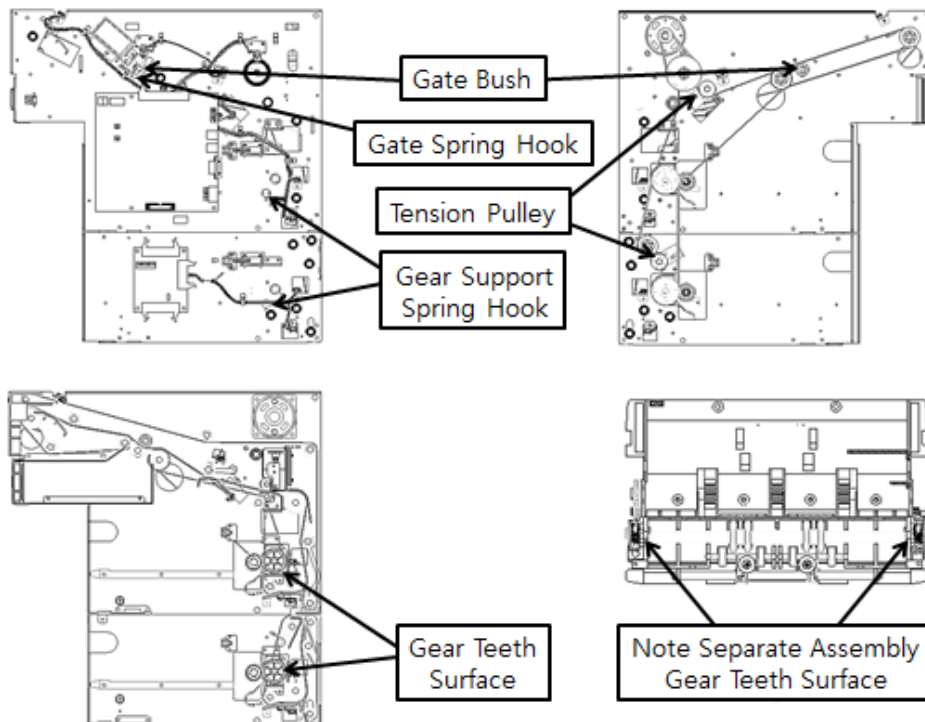

Cleaning Standard

- ▶ M6 : Once every 6 months / M3 : Once every 3 months.

| | Location | Int. | Remark |
|------------------------|--|------|--|
| CDU Main Body | CS1(A,B)D,T CS15(A,B)D,T CS4(A,B)D,T CS13D,T CS3 / CS8 CS7 / CS17 Guide entrance | M6 | Remove the foreign objects and dust using a soft brush |
| Note separate ASS'Y | Roller | M3 | Remove the foreign objects and dust using a soft brush |

Setting Specifications

► Dip S/W Specifications

1. Main B/D Dip S/W Specifications

| Dip S/W No. | Setting | Comments |
|-------------|---------|--------------------------------|
| 1 | On | Debug Console Mode |
| | Off | Default |
| 2 | On | Double Detect Sensor – 1 Lever |
| | Off | Double Detect Sensor – 2 Lever |
| 3 | On | Sensor Check Mode |
| | Off | Default |
| 4 | On | Test Mode |
| | Off | Online Mode |
| 5 | Unused | |
| 6 | Unused | |
| 7 | Unused | |
| 8 | Unused | |

2. Main B/D Dip S/W Default Setting

| | 1 | 2 | 3 | 4 | 5 | 6 | 7 | 8 |
|-----|---|---|---|---|---|---|---|---|
| On | | 0 | | | | | | |
| Off | 0 | | 0 | 0 | 0 | 0 | 0 | 0 |

3. FM B/D Dip S/W Setting

| | 1 | 2 | 3 | 4 | 5 | 6 | 7 | 8 |
|-----|---|---|---|---|---|---|---|---|
| On | 0 | | | | | 0 | 0 | |
| Off | | 0 | 0 | 0 | 0 | | | 0 |

Cable Connection Diagram

► Main Board

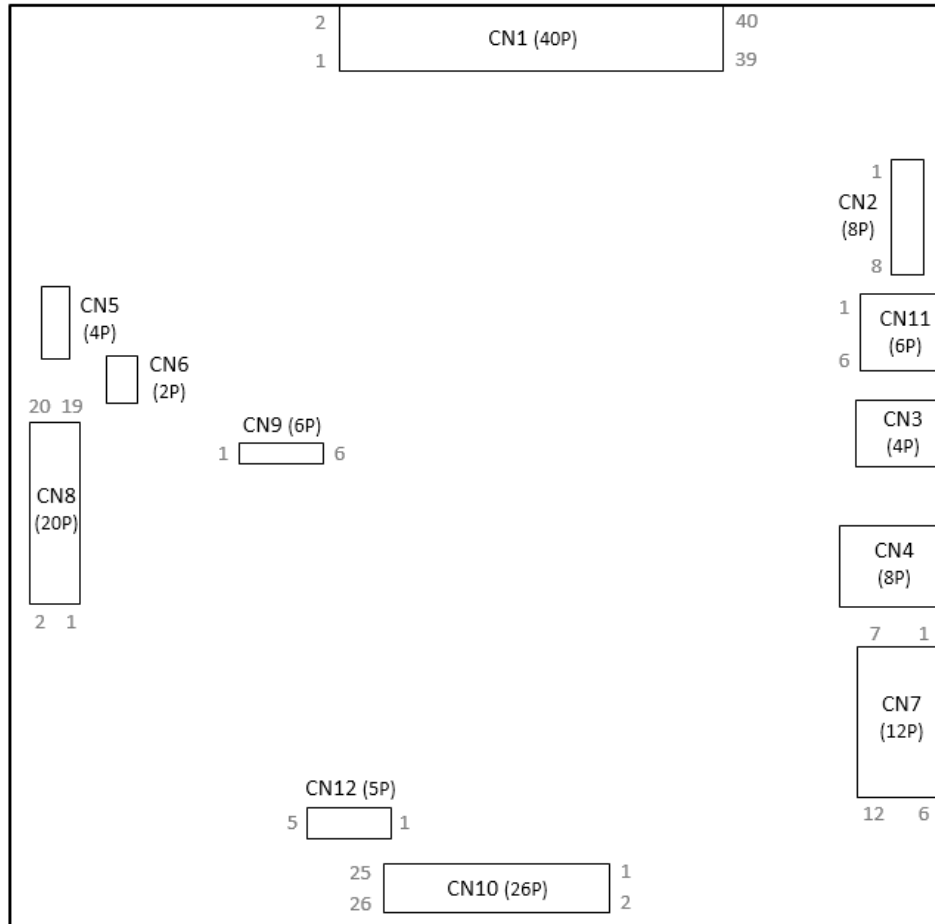

| No | Connector No. | Pins | Usage |
|----|---------------|------|------------------------------|
| 1 | CN1 | 40 | Sensors in Main Body |
| 2 | CN2 | 8 | DC Motor, Solenoid, Clutch |
| 3 | CN3 | 4 | USB I/F |
| 4 | CN4 | 8 | COM I/F (RS-232C) |
| 5 | CN5 | 4 | Debug Port (RS-232C) |
| 6 | CN6 | 2 | Debug Port (ISP) |
| 7 | CN7 | 12 | POWER (+24V, +12V, +5V, GND) |
| 8 | CN8 | 20 | JTAG (Debug) |
| 9 | CN9 | 6 | PLD Download |
| 10 | CN10 | 26 | FM BD I/F Conn. |
| 11 | CN11 | 6 | Sensors for Rear-type Unit |
| 12 | CN12 | 5 | 2 notes check Sensor |

Chapter 6

Receipt Printer

Contents

| | |
|--|------|
| Overview | 6-1 |
| Appearance and Dimension | 6-2 |
| Basic Specifications | 6-3 |
| Specifications of DIP S/W | 6-4 |
| Functional Description | 6-5 |
| Mechanical Adjustment..... | 6-7 |
| Preventive Maintenance | 6-9 |
| Cleaning | 6-10 |
| Lubrication | 6-11 |
| Removal/Installation Procedure for Field Technician..... | 6-15 |
| Sensor Replacement..... | 6-17 |
| Sub-assembly Replacement | 6-19 |

Overview

- ▶ The Receipt Printer is located on the left side when opening the front panel and can be divided into 3 assemblies.

Body Assembly

TPH (Thermal Printing Head) Assembly

Outlet Assembly

The Body Assembly contains the hopper for the paper roller and the controller board. Next to the hopper is a sensor that detects the paper low status and issues a warning. This Body Assembly has a mechanism that reduces the stress coming from the paper roll and maintains paper tension. Also, if an attendant inserts the paper into machine, it automatically sets the paper and performs an advance paper and cut.

TPH (Thermal Printing Head) Assembly is a printing engine equipped with a thermal printing head and a cutter. It prints out what has been commanded by the Host, cuts the printed output and sends it to the Outlet Assembly.

Outlet Assembly has a long transport section which enables landscape printing. It is also easy to maintain or repair in case of receipt jams because of its open structure.

Appearance and Dimension

► Appearance and Dimension

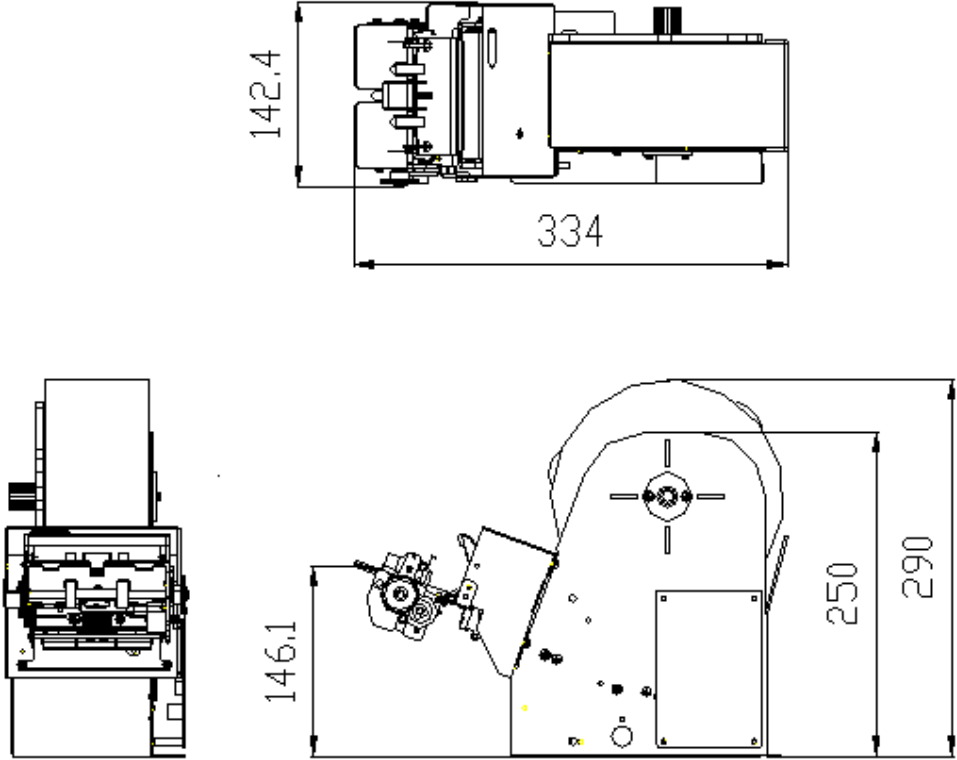

Basic Specifications

- Basic specifications of the Receipt Printer are summarized as follows.

| Item | | Specifications | Note |
|----------------------------|----------|---|---|
| Printing Type | | Thermal Line Printing Type(8dots/mm) | |
| Maximum Print Length | | 40 letters/line (based on Alpha Numeric value) | |
| No. of Print Lines | | Max. 21 lines/print (based on 1print=101mm) | |
| Valid Printing Width | | Max. 91mm | |
| Type of Printer Letter | | English / Number, Latin | |
| Paper | Type | External Printing Thermal Paper | |
| | Width | 79.5±0.5mm | |
| | Exterior | Max. φ180mm | |
| Type of Paper Setting | | Semi-Auto loading | |
| Type of Receipt Dispensing | | Dispensed separately | |
| END Detection Function | | Yes | |
| Number of Transaction | | About 4,100 transactions/roll (Φ180) | Based on 1 transaction = 101mm (thin type: 55g paper) |

Specifications of DIP S/W

▶ DIP S/W

| DIPS/W | Function | Setting | |
|--------|--|----------|-----|
| 1 | Reserved | Reserved | |
| 2 | Setting whether or not to use black mark paper | ON | OFF |

▶ LED Status

| LED | Function |
|-----|---|
| 1 | Check the power availability |
| 2 | STATUS LED(OFF-Line = OFF , On-Line=On, Error=Blink |

Functional Description

► There are 3 major functions of the Receipt Printer as follows.

1. Checking the status of the machine and setting paper.
 - Print Start (Thermal Printing Head Fire)
 - Black Mark Start and Stop
 - Cutting
3. Ejecting
 - Releasing the cut paper respectively

► Layout of sensor and actuator

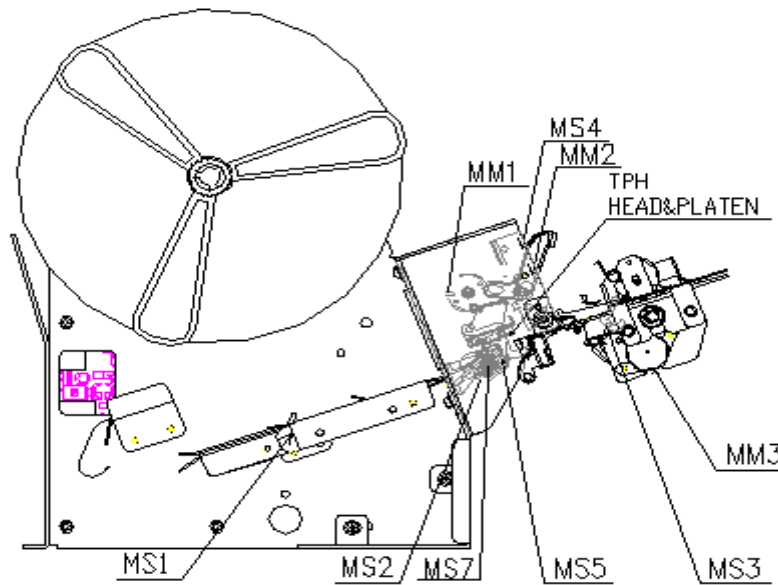

► Distance between sensor and actuator roller (Approximately)

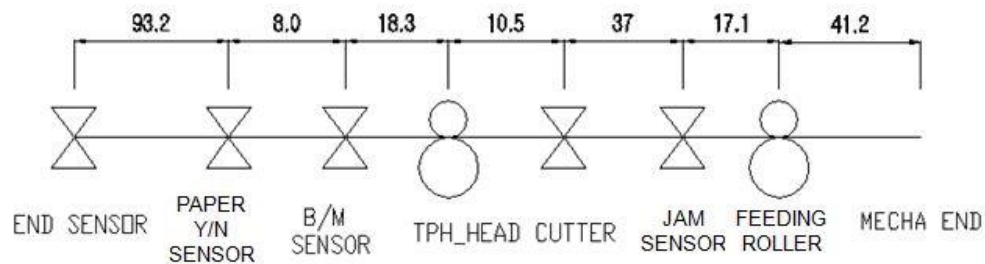

- The symbols, names, and major functions of each sensor and electromagnetic component are summarized in the following table.

| NO | SYMBOL | NAME | MAJOR FUNCTIONS | DEFAULT VALUE |
|----|--------|--------------------------|---------------------------|---------------|
| 1 | MS1 | END DETECTION SENSOR | END DETECTION | DEFAULT:OFF |
| 2 | MS2 | PAPER EMPTY CHECK SENSOR | PAPER EMPTY CHECK | DEFAULT:OFF |
| 3 | MS3 | JAM SENSOR | PAPER JAM SENSOR | DEFAULT:OFF |
| 4 | MS4 | CUTTER SENSOR | CUTTER LOCATION DETECTION | DEFAULT:ON |
| 5 | MS5 | TPH OPEN SWITCH | TPH HEAD OPEN DETECTION | DEFAULT:ON |
| 6 | - | - | - | - |
| 7 | MS7 | BLACK MARK SENSOR | BLACK MARK DETECTION | DEFAULT:OFF |
| 8 | MM1 | TRANSPORTING MOTOR | PAPER TRANSPORT | DEFAULT:OFF |
| 9 | MM2 | CUTTER MOTOR | CUTTER OPERATION | DEFAULT:OFF |
| 10 | MM3 | FEEDING MOTOR | PAPER FEED | DEFAULT:OFF |

The major detection functions of the above sensors and electromagnetic components include paper empty check by section, checking the status of “cutting” using the cutter position switch, OPEN/CLOSE detection of the TPH cover, and detection of the TPH overheating and paper jams.

Mechanical Adjustment

► When disassembling or assembling any components or assemblies in the field, it is essential to follow the proper adjustment specifications recommended by Hyosung. Performing the correct adjustment can have a critical impact on the lifespan of the component. If the adjustment is incorrect, the problem may not appear during the initial testing, but the lifespan of the component can be shortened considerably. In addition, incorrect adjustment can cause such problems such as receipt jams.

► Adjustment of the Guide Inlet

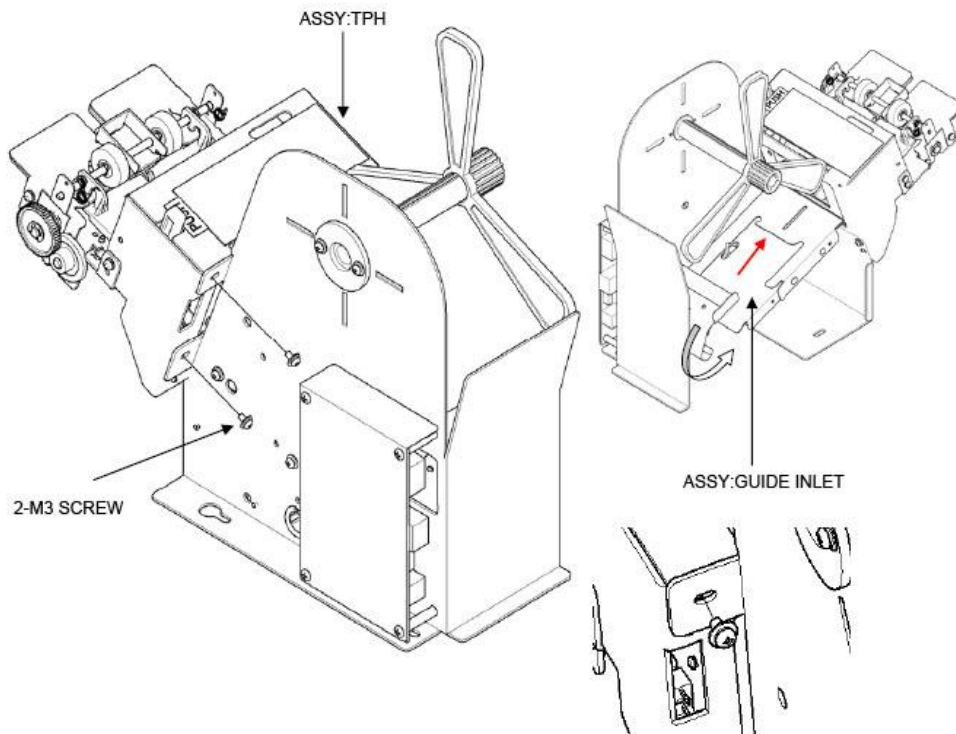

1. Adjust the Entrance of the ASSY:GUIDE INLET and the ASSY:TPH
 - Closely put the screw on the left of Oblong of the Frame and half tighten it.
 - Insert the paper in the direction of red arrow and check if the paper is smoothly inserted.
 - Then tighten the screw completely.

CAUTION:

- 1) Be sure to understand the operation of adjustment section.
- 2) Grasp the order of adjustment and follow the order in this manual.
 Unless there are special precautions, half tighten the screws and nut.
 After finishing adjustment, completely tighten them.
- 3) If not specially designated, follow the tightening torque in the table.

| Classification | Type | Torque |
|----------------|-------|--------|
| M2, 6 | Screw | 4Kg·cm |
| M3 | Screw | 6Kg·cm |

- 4) For easy adjustment, remove the part or the assembly. When reassembling them, check again all related adjustment influenced by this work.
- 5) For the rattling noise of link cover, perform the adjustment in the direction which the related behavior occurs less.

Preventive Maintenance

- ▶ Perform the following steps after you have made repairs or cleared paper jams.
 1. Remove all accumulations of dust and paper residue from the unit using a brush and cleaning rag. Any debris left may be blown away using canned air. Make sure that you clean the surfaces of every sensor on the SPR by using foam or cotton tips. Any cracked or broken sensors must be replaced.
 2. Open the Print head assembly and using canned air, blowout any dust or debris inside this area.
 3. Ensure that all transport belts are in the correct pulley position. If belts continuously get out of place, this is a good indication of wear and the module needs to be replaced.
 4. Ensure printing records are printed clear and legible.
 5. After you have repaired and performed your preventive maintenance, it is imperative that you run diagnostics to fully test the unit.
 6. Fill out the ATM Repair Log Sheet

▶ Regular Inspection and Cycle

Items to be regularly inspected and cycles are as follows:

| No | Regular Inspection and Item | Cleaning | Check | Adjustment | Lubrication | Inspection Cycle | Note |
|----|---|----------|-------|------------|-------------|------------------|------|
| 1 | Sensor Check & Cleaning | | ○ | ○ | | Every 6 months | |
| 2 | Transport Path Cleaning | ○ | ○ | | | Every 6 months | |
| 3 | Feeding Motor Gear Inspection & Lubrication | | ○ | | ○ | Every 6 months | |
| 4 | TPH & Platen Cleaning | ○ | ○ | | | Every 6 months | |

Cleaning

- ▶ In order to prevent problems caused by the dirt or debris of the electromagnetic components on the transport path, it is important to strictly follow the cleaning cycles and methods described in this section.

- ▶ Sensor
Using a cotton swab or a Q-tip, eliminate foreign substances like dirt or waste. After cleaning, check the sensor by conducting a Self Test, and check at least 3 times the cleaning status, angle of the sensor, and the accuracy status of the assembly. If it is defective, replace the sensor with a new one.

- ▶ Transport path
Turn off power, and reciprocate the cleaning brush a number of times to clean the components (Roller, Cutter, etc.) on the Transport Path. Prevent static electricity occurring on the TPH print head by being careful not to touch it with your hands.

- ▶ TPH & Platen
Turn power off and open the Platen Open Lever (Green). Wipe the Heat Element and the Platen with cotton soaked in ethanol, methanol, or IPA. After the cleaning substance has evaporated, place the Platen at the normal operating position.

- ▶ Other Cautions
When transporting the Receipt Printer assembly, hold it with two hands under the printer. Do not hold the print release section of the assembly. For repairing the Receipt Printer, do not forget to place it on the flat surface. There must be no shaking or interventions from other objects.

Lubrication

► Lubrication Standard

1. Check the oiling status before running or storing the receipt printer. If needed, apply lubricant to the corresponding part in compliance with the oiling standard.
2. Apply grease only if necessary during the regular field inspection. If there is enough lubricant, do not apply additional lubricant. However, if lubricant is contaminated, remove the old lubricant before applying new.
3. All pivot points and frictions parts must be oiled.
4. All points except the following must be oiled:
Printing head, Magnetic head, Package, Micro switch contact, Drive roller, Timing pulley, and Timing belt
5. All oiling operations must be based on oil drop unit. However, when contact between the oiling device and the oiling target is unavoidable, the contact time must not exceed one second.

► Precaution during lubrication

1. Lubricant must not leak. In other words, lubricant must be applied only to the parts that need oiling. Do not apply excessive lubricant. Lubricant must not contaminate other parts. Be careful that the micro switch, sensors, the timing pulley, the timing belt, the controller board, the print head, and the magnetic head are protected from lubricant.
2. Do not clean plastic parts or protection devices with alcohol and other agents other than the designated one.
3. Remove dust, oil, and grease from the assembly and clean with a dry soft cloth.
4. Be careful that the paper contact areas in the paper return path is protected from lubricant.
5. Lubricant Types

| Type | Name | Note |
|------------|--------------------------|------|
| Grease(G1) | Shell Albania Grease EP1 | |
| Tellus Oil | Shell Tellus #100 | |

6. Lubrication Symbol & Description

| Symbols | Description |
|---------|--|
| OF | Dip a number 2 brush in oil and squeeze oil from the brush not to drop the oil. Then lubricate only to the extent that the surface of the target is wet. |
| O | Dip a number 2 brush in oil and lubricate the entire surface of the target lightly. |
| O1 | Lubricate a single drop. (Oiling amount : 15mg) |
| G | Using a brush under the number 10, coat a lubrication position with Grease lightly. |

<Note!>

- 1) The lubrication amount of 15mg is equivalent to a single drop by a lubricating tool 0.8 ~1.2 mm in diameter and 30mm in length.
- 2) Grease 0.1g is equivalent to 12mm squeezed by Grease gun 7mm in a diameter.

7. Symbols about lubrication cycle

| Lubrication cycle | Description |
|---------------------|----------------------------------|
| Initial Lubrication | Only 1 lubrication at first time |
| M6 | Every 6 months |
| Y1 | Every year (including M6) |

► Lubrication Point

Support engineering recommends that the SPR gets lubricated every 6 months. All lubrication points illustrated must be checked and lubricated if necessary. Before you apply any type of lubricant, it is imperative to wipe off any of the old lubricant left on the assembly. The SPR does not require much lubrication. There are only 2 types of lubricants designated to be used in this assembly and they should be applied on specific locations illustrated on the following images.

Greasing: When applying grease, it is CRUCIAL to clean and apply a very light amount on the designated areas, especially gears.

Oiling: It is imperative to clean the components first and then apply a very light amount of oil.

AREAS NOT SPECIFIED IN THIS DOCUMENT, DOES NOT REQUIRE LUBRICATION.

MAKE SURE Belts, Print head, Micro Switches, Timing Gears and Drive Rollers IN THE SPR ARE "NOT" CONTAMINATED WITH ANY LUBRICANT. THIS MAY DAMAGE OR CHANGE THE FUNCTIONALTY OF THE COMPONENT.

1. Lubrication point 1- Spring Hook

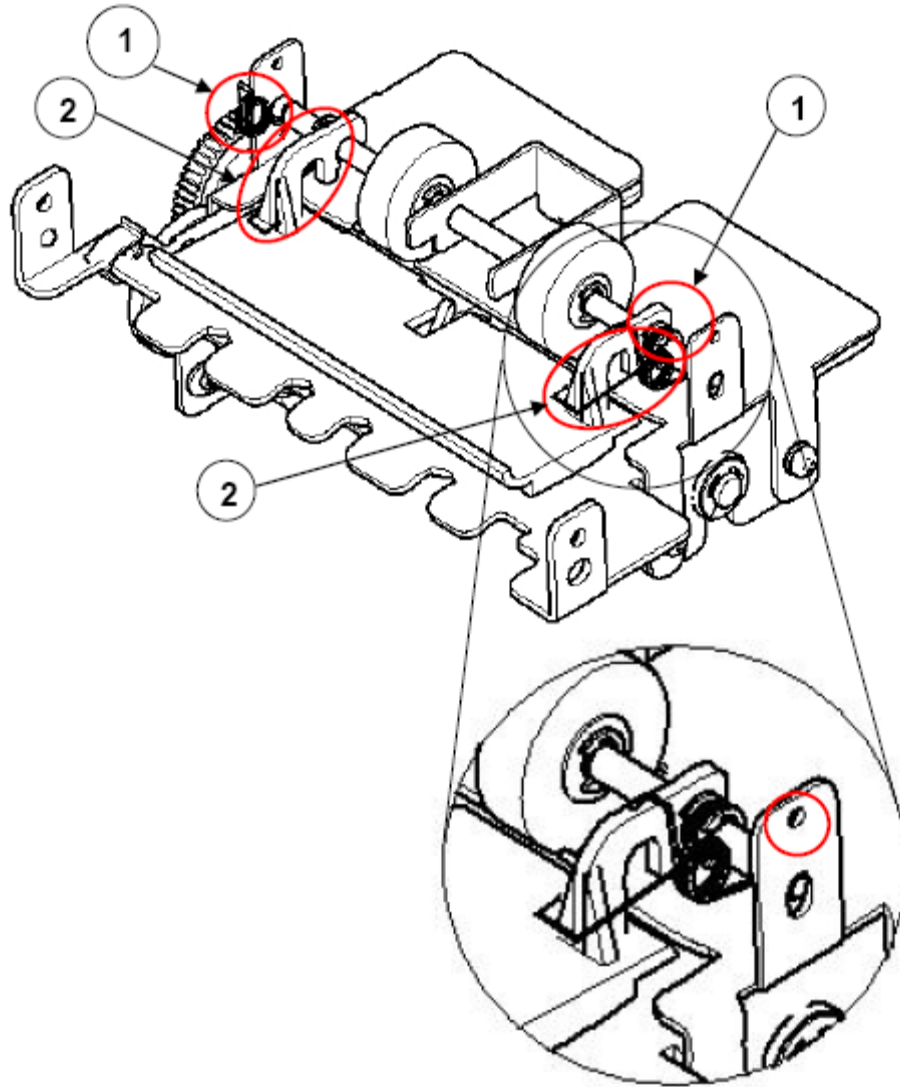

| No | Part Name | Lubrication Point | Lubrication Type | Lubrication Amount | Cycle | Note |
|----|------------------------------|------------------------------|------------------|--------------------|-------|---------|
| 1 | SPRING: ROLLER | Spring Hook and Bracket Loop | G1 | G | M6 | 2places |
| 2 | SPRING: SUPPORT_UP PER GUIDE | Spring Hook and Bracket Loop | G1 | G | M6 | 2places |

2. Lubrication Point 2 - Gear

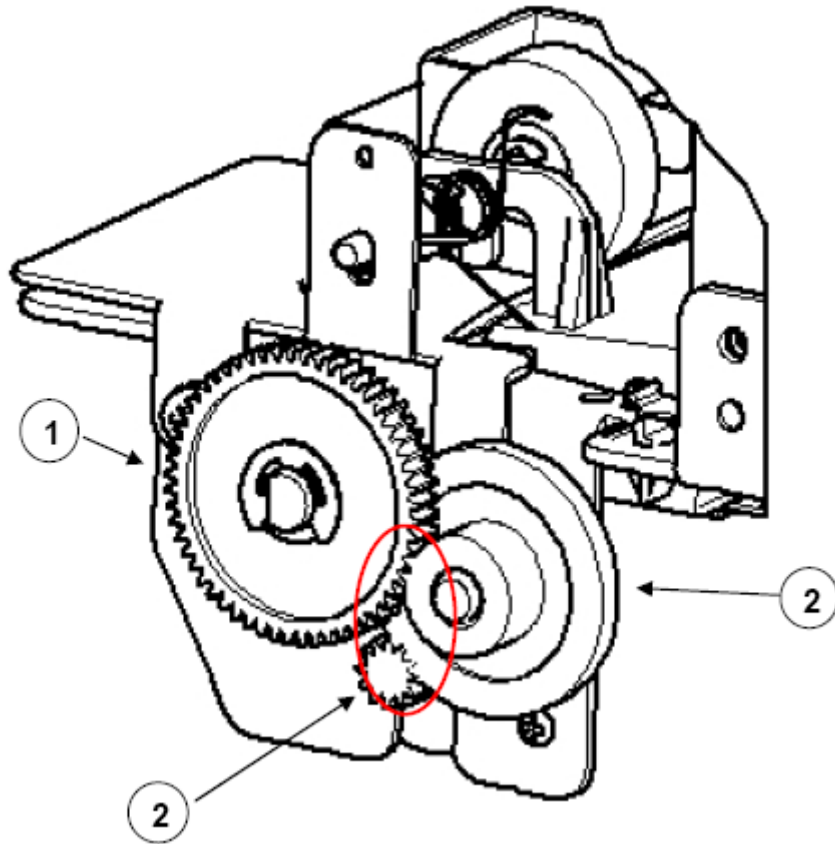

| No | Part Name | Lubrication Point | Lubrication Type | Lubrication Amount | Cycle | Note |
|----|-----------------------|-----------------------|------------------|--------------------|-------|--------|
| 1 | ROLLER:PHI28.9X10:TPH | Between Gear and Gear | G1 | G | M6 | 1place |
| 2 | IDLE_2 | Between Gear and Gear | G1 | G | M6 | 1place |
| 3 | STEP_PM20S-020-ZKY8 | Between Gear and Gear | G1 | G | M6 | 1place |

Removal/Installation Procedure for Field Technician

- There are several parts or assemblies that can be replaced in the field. In order to repair other components, the entire receipt printer should be replaced at the Depot level. Note however, that this is just a recommendation and can be adjusted depending on field conditions or the capability of the technician.

| Section | Location Detail | Remark |
|--------------------------------------|-----------------|------------------------|
| Entire Unit | Receipt Printer | Field technician Level |
| Sensor | MS1, MS3 | |
| Controller Board | | |
| Motor | | |
| Outlet guide | | |
| Other components not mentioned above | | Depot Level |

- For repair of the assembly, it is easy to disassemble the printer into 3 assemblies as shown below,

1. How to easily take apart the Assembly 1

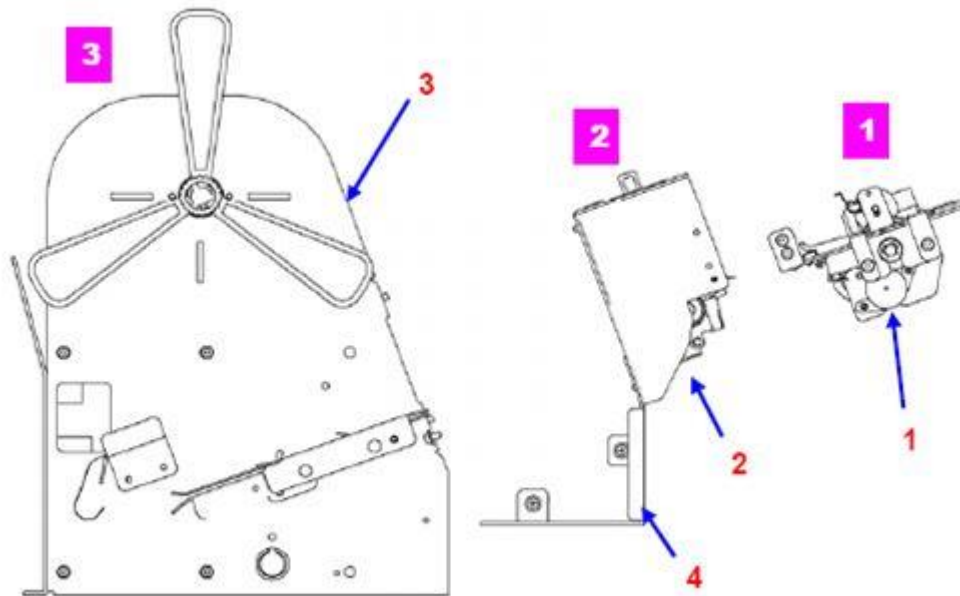

| | | | | | |
|---|-----------|----------------------|---|----------|------------------------|
| 1 | 72881301 | ASSY:OUTLET | 3 | - | BODY |
| 2 | 732000123 | ASSY: TPH_SUPPORT | 4 | 45682601 | BRKT: TPH_SUPPORT_2 |

► How to easily take apart the Assembly 2

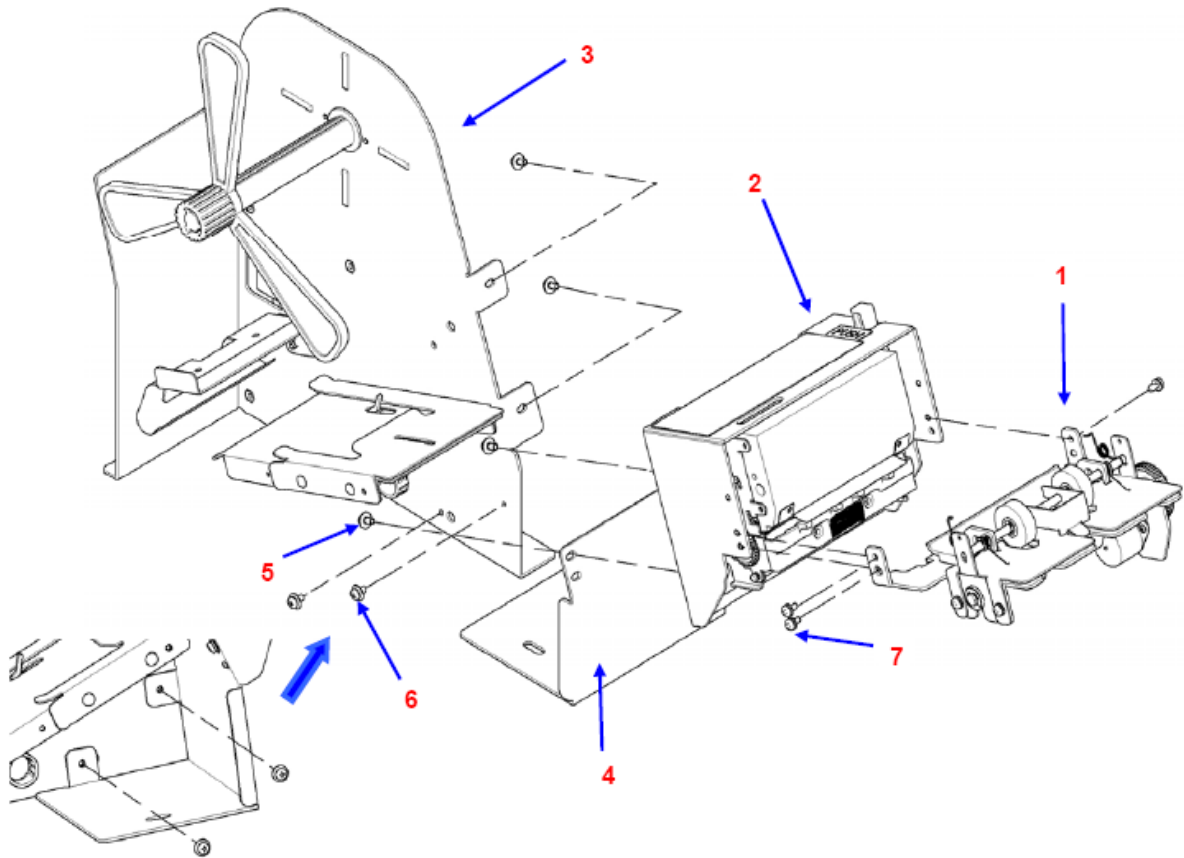

| | | | | | |
|---|----------|-----------------|---|----------|---------------------|
| 5 | 44651302 | SCREW:M3X6 (X4) | 6 | 44651302 | SCREW: M3X6 (X2, L) |
|---|----------|-----------------|---|----------|---------------------|

1. Unfasten the screws (5) to separate the TPH assembly & TPH support bracket (2, 4) from the body (3).
2. Unfasten the screws (6) to separate the TPH assembly & TPH support bracket (2, 4).
3. Unfasten the screws (7) to separate the Outlet & TPH assembly (1, 2).

Sensor Replacement

► MS1 (End Detection) Sensor

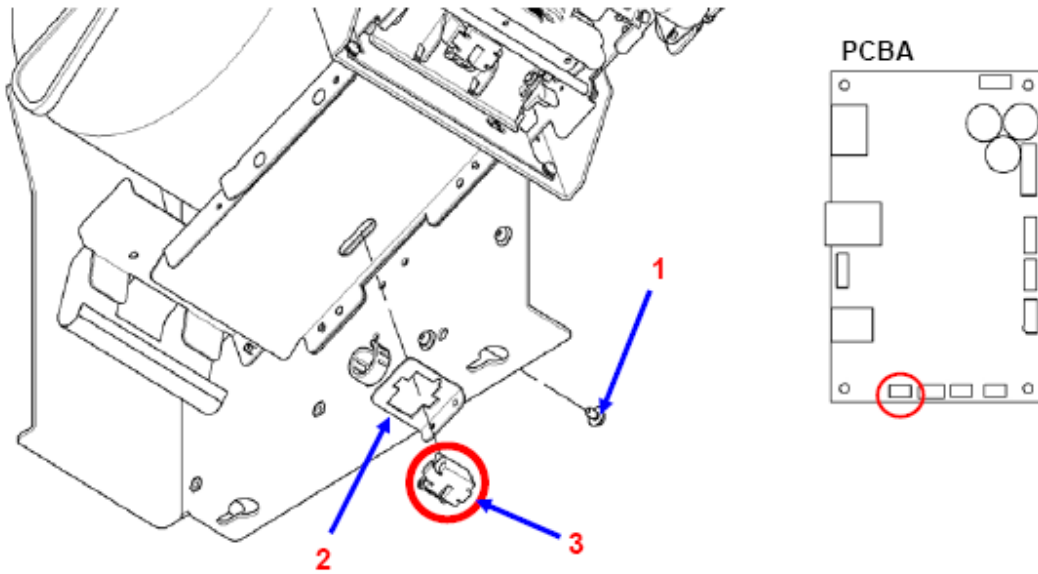

| | | | | | |
|---|----------|-----------------|---|----------|----------------------|
| 1 | 44651202 | SCR:M2.6X6 | 3 | 21685601 | SENSOR:P-INTERRUPTER |
| 2 | 45682001 | BRKT:END_SENSOR | | | |

1. Remove the screw (1) and disassemble the sensor assembly.
2. Separate the sensor (3) from the sensor assembly bracket (2).
3. Disconnect the connector connected to the PCBA on Main Frame.
4. To assemble again, use the reverse order.

<Note!> Refer to the highlighted part by the blue circle in the below picture.

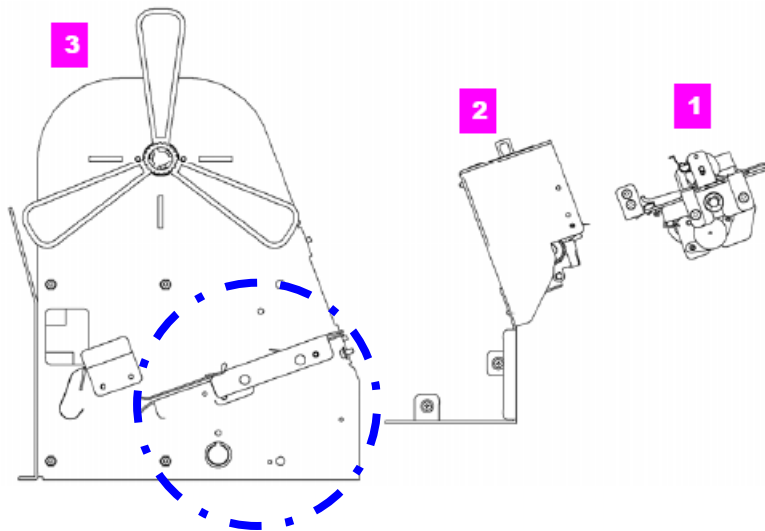

► MS3 Sensor (Jam_Sensor)

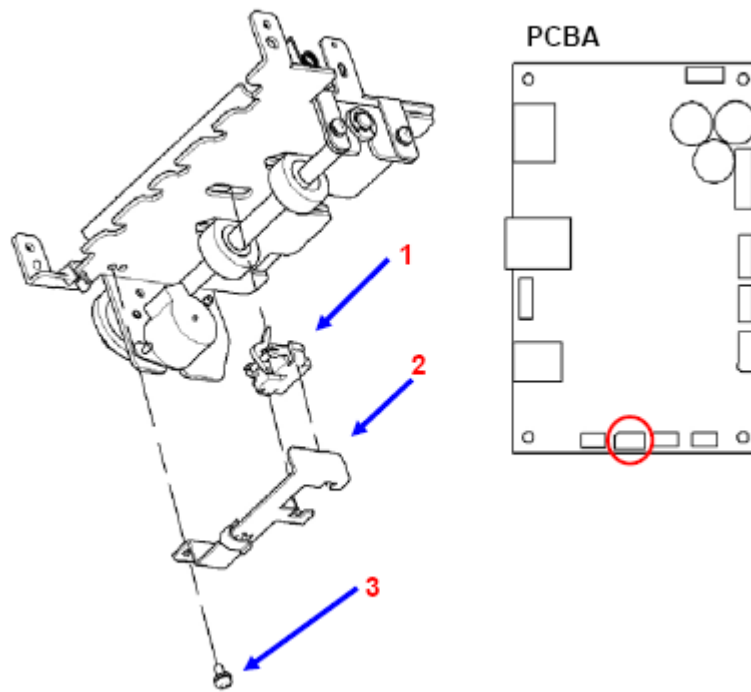

| | | | | | |
|---|----------|------------------------|---|----------|--------------|
| 1 | 21685601 | SENSOR : P-INTERRUPTER | 3 | 44651202 | SCR : M2.6X6 |
| 2 | 45682201 | BRKT : JAM_SENSOR | | | |

1. Remove the screw (3) and separate the sensor from the MS3 sensor bracket (2, BRKT : JAM_SENSOR). And then replace it as new one.

<Note!>: Refer to the highlighted part by the blue circle in the below picture.

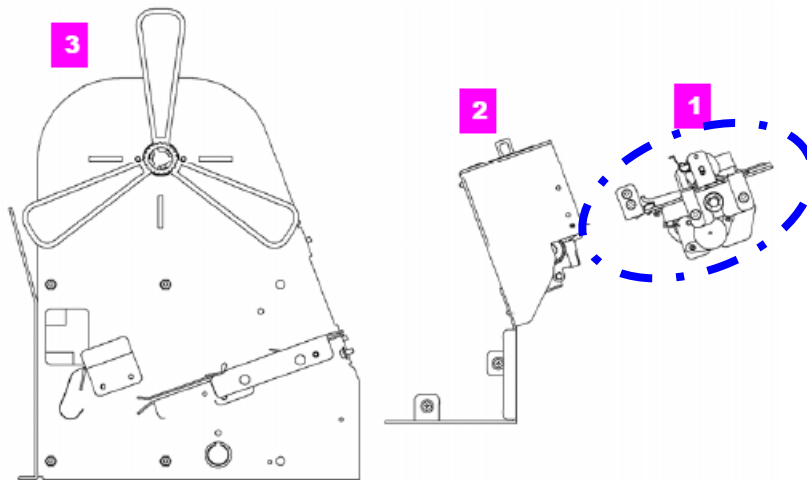

Sub-assembly Replacement

► Thermal Printing Head

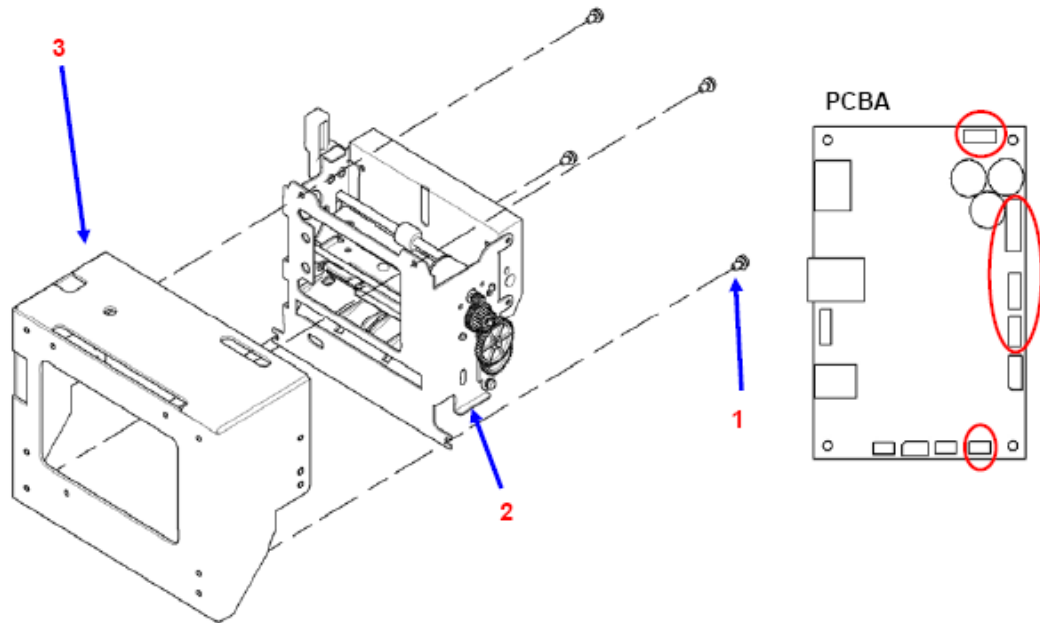

| | | | | | |
|---|------------|-----------------|---|----------|--------------------|
| 1 | 44651202 | SCR:M2.6X6 (x4) | 3 | 45682502 | BRKT : TPH_SUPPORT |
| 2 | 5677000018 | KPC_72_KC62 | | | |

1. Remove screws (1, X4) and disassemble TPH (Thermal Printing Head). Then replace it as new one.

<Note!> Refer to the highlighted part by the blue circle in the below picture.

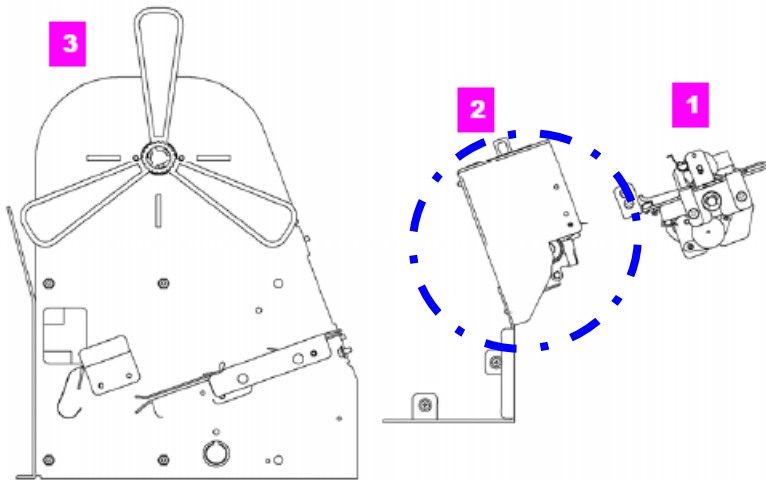

When taking out the Print Head, be careful not to damage the FFC Cable. Make note of the cable orientation on the PCB before disconnecting. Match the Pin configuration when re-assembling the FFC Cable to the Control Board.

<Note!> Insert HEAD OPEN LEVER into the interference evacuation zone when assembling TPH and TPH_SUPPORT.

<Warning!> Since the FFC Cable has different voltages (+3.3V, +5V,+12V,+24V) connected together, it is very important to match the correct Pin configuration when re-assembling a cable to the connector. Damage to the control board can occur if the cables are not connected properly.

<Reference!> The regular replacement cycle of TPH Assembly is as follows:

| | Part Number | Replacement Cycle | Note |
|--------------|-------------|-------------------|------|
| TPH Assembly | 7320000123 | every fifth year | 70km |

► Guide Replacement

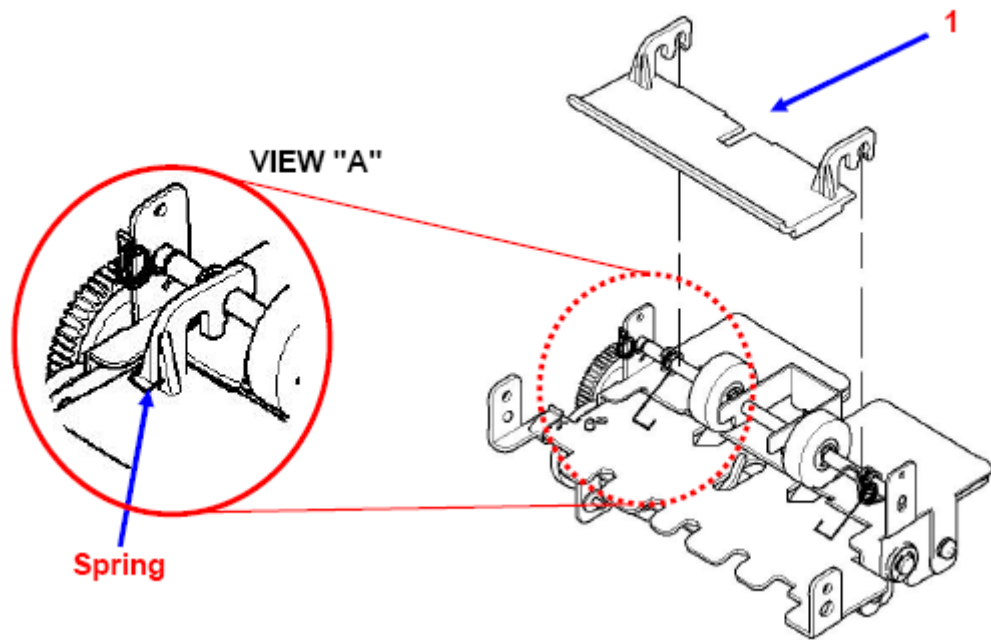

| | | |
|---|----------|-----------------|
| 1 | 45424101 | GUIDE:SPR_UPPER |
|---|----------|-----------------|

1. Lift up the spring (see VIEW "A" in the above picture) and replace the guide.

<Note!> Refer to the highlighted part by the blue circle in the picture below.

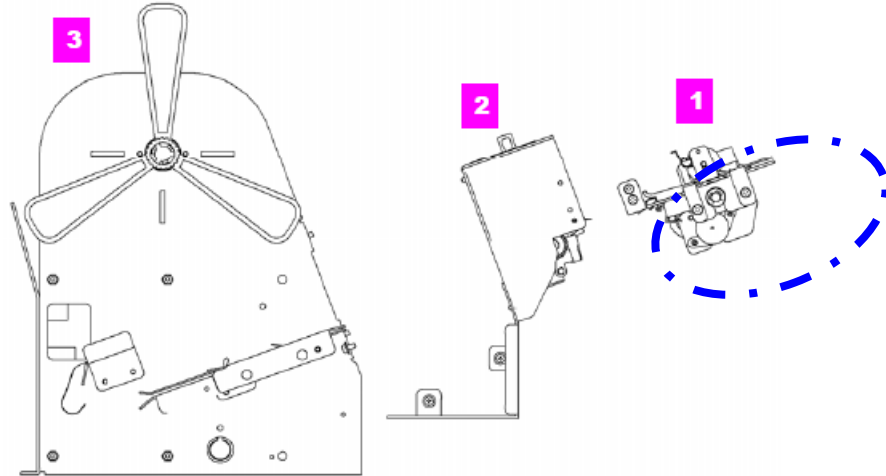

► Motor Replacement

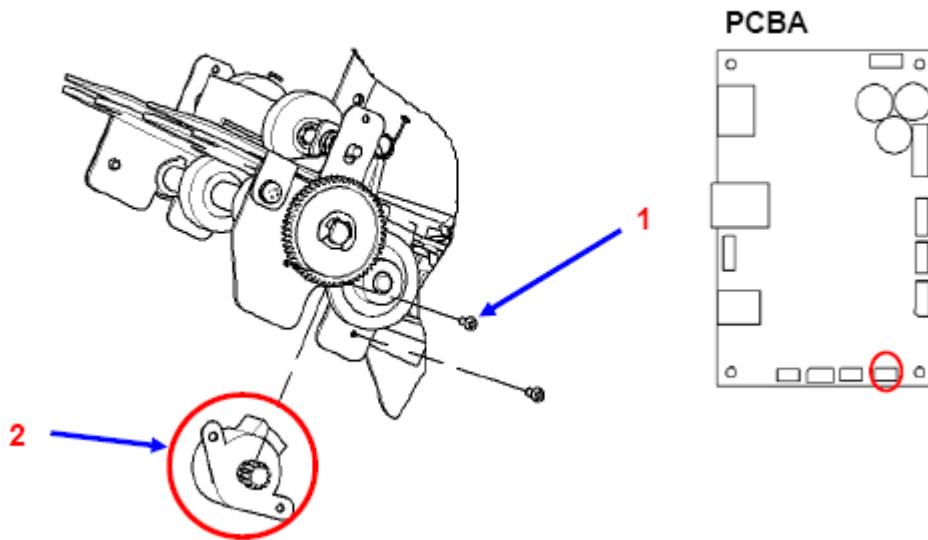

| | | | | | |
|---|----------|-----------------|---|----------|-----------------------|
| 1 | 44610302 | SCR:M2X6 (x2ea) | 2 | 56405701 | MOTOR: PM20S-020-ZKY8 |
|---|----------|-----------------|---|----------|-----------------------|

1. Remove the screws (2ea, 1) and replace the motor.

<Note!> Refer to the highlighted part by the blue circle in the below picture.

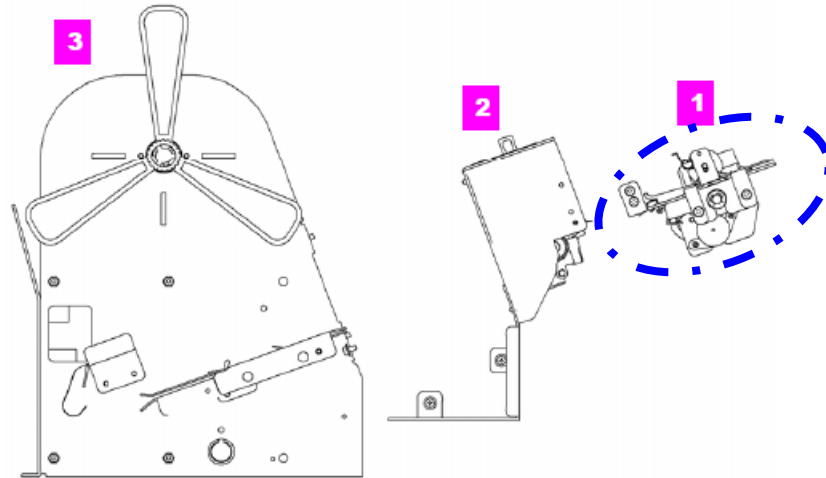

► Control Board Replacement

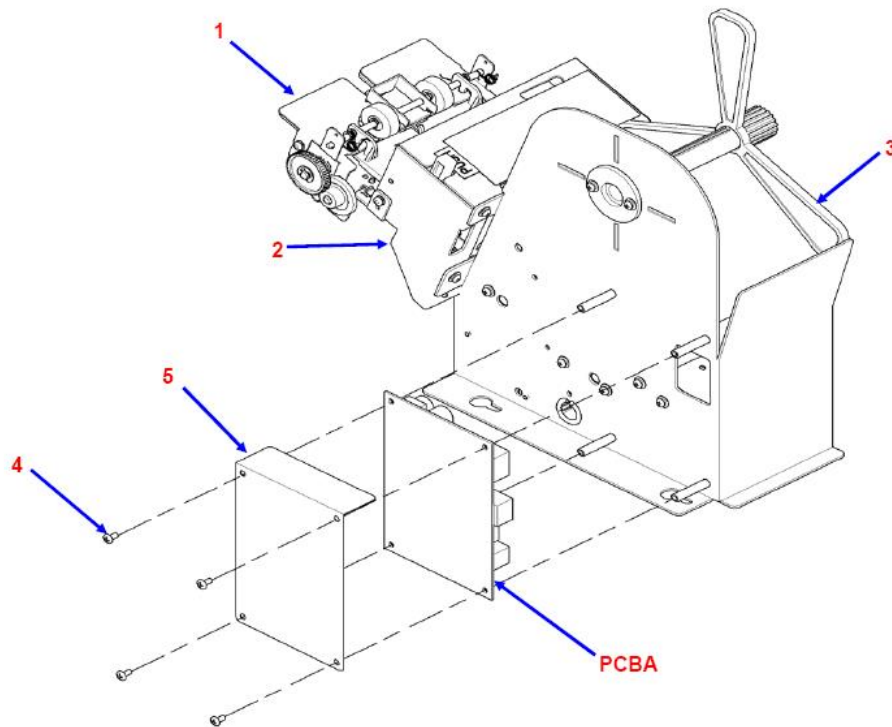

| | | | | | |
|------|---|------------------|---|------------|--------------------|
| 1, 2 | - | ASSY:OUTLET, TPH | 4 | 44660306 | SCR:BH:M3X6 (x4ea) |
| 3 | - | MAIN BODY | 5 | 4605000255 | COVER:PCBA |

1. Remove the screws (4) and separate PCBA (Control Board) from the body (3).

<Note!> Refer to the highlighted part by the blue circle in the below picture.

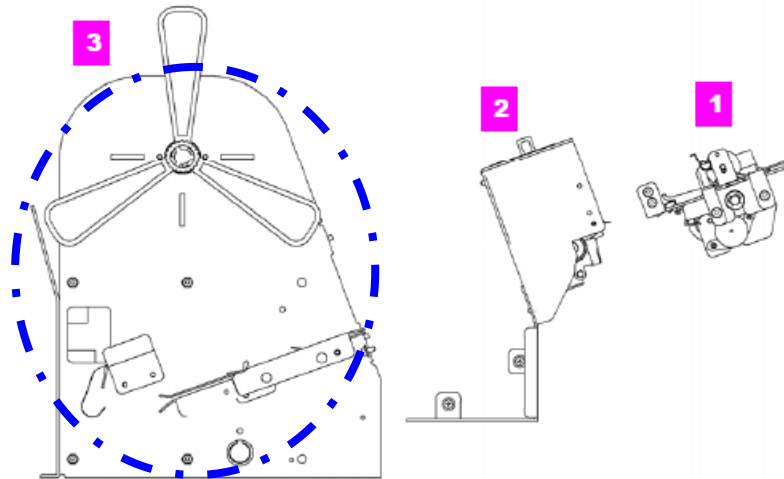

► Spring Replacement

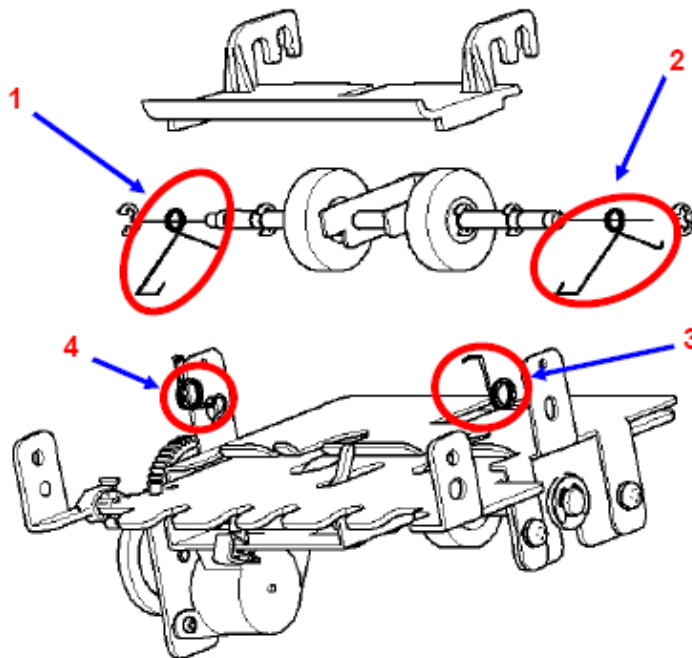

| | | | | | |
|---|----------|-------------------------|---|----------|---------------------------------------|
| 1 | 44949001 | SPRING: ROLLER_LEFT | 3 | 43252801 | SPRING: SUPPORT_UPPER_ GUIDE_RIGHT |
| 2 | 44949002 | SPRING: ROLLER_RIGHT | 4 | 43252802 | SPRING: SUPPORT_UPPER_ GUIDE_LEFT |

1. Replace the spring assembled on the ASSY:OUTLET referring to above picture.
2. After replacing the spring, be sure to perform the lubrication. (Refer to “Lubrication”)

<Note!> Refer to the highlighted part by the blue circle in the below picture.

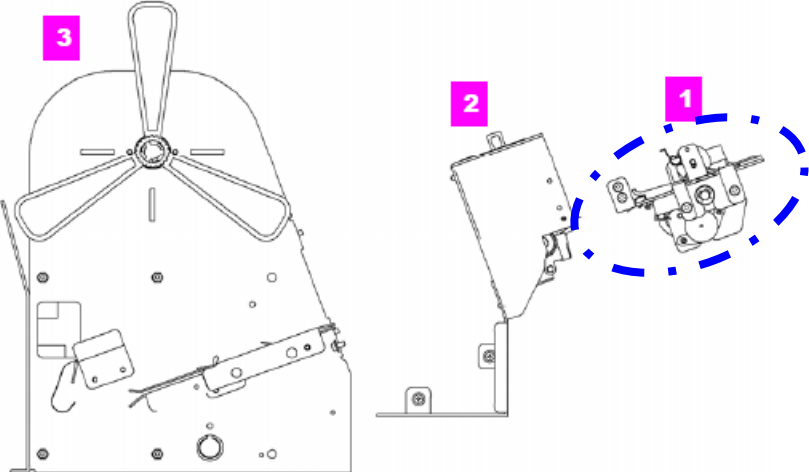

Notes